

STANDARD AND OPTIONAL EQUIPMENTS

● Safety equipments

	STD	LC
ISO 12117-2 ROPS cab (with ISO 10262 FOPS top guard LEVEL I)	●	●
Safety lock lever	●	●
Seat-belt	●	●
Emergency engine stop switch	●	●
Emergency escape hammer	●	●
Rear view mirrors (right&left side)	●	●
Rear view Camera	●	●
Right side view camera	●	●
Working light (slewing table right side,boom left side)	●	●
Additional working lights (cab left and right side)	●	●
Additional working light (boom right side)	●	●
LED working lights	●	●
Boom/Arm anti-drift valves	●	●
Slewing anti-counter action	●	●
Automatic parking brake (swing)	●	●
Automatic parking brake (traveling)	●	●
Fire walls	●	●
Falling prevention handrail	●	●
Battery disconnect switch	●	●
Caution indication signs	●	●
Cab lower guard	●	●
Cab front guard	●	●
Cab head guard	●	●
Step on side of cab	●	●
Fire extinguisher	●	●
Additional electric horns	●	●
Traveling alarm	●	●
Swing interlocking warning lamp	●	●
Loud speaker	●	●

● System

	STD	LC
APC modes (A, P and E)	●	●
Front attachment mode	●	●
Auto-slow, one touch slow	●	●
Automatic transmission for traveling	●	●
2 speed modes for traveling	●	●

● Cab

	STD	LC
6points viscous dampling cab suspension	●	●
Pull up front windshield	●	●
7 inch touch screen control LCD monitor	●	●
Double slide operator's seat	●	●
Seat suspension adjustable to operator's weight	●	●
Automatic air conditioner (pressurized)	●	●
Defroster	●	●
Large capacity warming & cooling insulation box	●	●
Intermittent windshield wiper	●	●
AM/FM radio	●	●
Two stereo speakers	●	●
LED interior light	●	●
Cup holder	●	●
Helmet hook	●	●
24V electric supply port	●	●
Transparent roof hatch with sun shade	●	●
Sun shade	●	●
Sun visor	●	●
Rain visor	●	●
Ash tray (with cup holder)	●	●
12V electric supply port	●	●
USB ports (x2, total 2.5A)	●	●
Seat cover	●	●

● Piping and other

	STD	LC
Attachment service port (1spool)	●	●
High performance return filter	●	●
Additional piping for breaker & crusher	●	●
Accumulators for breaker	●	●
Boost piping for crusher	●	●
Additional piping (for rotator)	●	●
Lowering control device (boom)	●	●
Lowering control device (arm)	●	●
Control pattern change valve (ISO-SAE)	●	●
Air cleaner double elements	●	●
Pre-cleaner (automatic dust eject)	●	●
Increased counter weight (+500kg)	●	●
Reinforced under cover (slewing table)	●	●
Electric refuelling pump	●	●
Electric grease gun	●	●
Specification for cold region	●	●
Designated painting	●	●
Tool set	●	●



● Working equipments

	STD	LC
Bucket	0.7m ³ bucket	●
	1.1m ³ bucket	●
	1.4m ³ bucket	●
	1.6m ³ bucket	●
	1.8m ³ bucket	●
	1.4m ³ reinforced bucket	●
	1.4m ³ bucket (side-pin tooth)	●
	1.6m ³ bucket (side-pin tooth)	●
Arm	3.14m standard arm	●
	3.14m reinforced arm	●
	4.14m long arm	●
	Various type of reinforcements	●
Boom	6.48m standard boom	●
	6.48m reinforced boom	●
	Bracket for small swing radius	●
	Various type of reinforcements	●
Link	Standard side link	●
	Reinforced side link	●

● Traveling equipments

	STD	LC
Shoe	600mm with triple grouser	●
	600mm reinforced with triple grouser	●
	700mm with triple grouser	●
	800mm with triple grouser	●
	914mm with triple grouser	●
Track guard	1 Piece each side	●
	3 Pieces each side	●
	Full truck guard	●
Covers on the bottom face of traveling frame	●	●
Reinforced traveling motor cover	●	●
Traveling frame with motor case reinforcement	●	●

● Standard equipments ● Option — No setting

BUCKET						
Type of bucket		Hoe bucket				
Bucket capacity	m ³ , ISO	0.70	1.10	1.40	1.60	1.80
Bucket width	W/O side cutters, mm	750	1,100	1,290	1,475	1,660
	with side cutters, mm	860	1,210	1,400	1,590	—
Number of bucket teeth		3	4	5	6	6
Shape of bucket						
Standard boom +	Standard arm (3.14m)	●	●	●	▲	□
	Reinforced (3.14m)	●	●	●	▲	□
	Long arm (4.14m)	●	□	×	×	×

- : General purpose (used with material weight 1,800kg/m³ or less)
- ▲ : Light work (used with material weight 1,600kg/m³ or less)
- : Loading only (used with material weight 1,100kg/m³ or less)
- × : Unusable
- Yellow colored area means standard.

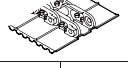
TRACK SHOES						
Type of shoes		Grouser shoe				
						
Specifications for main body	Shoe width	mm	600	700	800	914
	Overall width	mm	3,190	3,290	3,390	3,510
	Operating weight	kg	32,000 [32,800]	32,330 [33,150]	32,890 [33,750]	33,590 [34,490]
	Ground pressure	kPa	64 [61]	55 [52]	48 [46]	42 [40]

Operating weight and Ground pressure figures, with 6.48m standard boom, 3.14m standard arm and 1.4m³(ISO) bucket.
● Yellow colored area means standard. [] HD1430LC-7

<http://www.kato-works.co.jp>

NOTE : Illustrations may include optional equipment. KATO products and specifications are subject to improvements and changes without notice. Mentioned figures are approximate.

● Contact for enquiry:



KATO WORKS CO.,LTD.

9-37, Higashi-ohi 1-chome, Shinagawa-ku, Tokyo 140-0011, Japan.
Tel. : Head Office Tokyo(03)3458-1111
Overseas Marketing Department Tokyo(03)3458-1115
Fax. : Tokyo(03)3458-1163



HD1430-7
REGZAM | HYDRAULIC EXCAVATOR

Low-Fuel Consumption and Powerful Performance

Environmentally-friendly

- US EPA Tier 4 and EU StageIV compliant engine

Complete operation

- New control valve reduces the fuel consumption

Safety

- New ROPS (Roll-over Protective Structure) cab
- New engine neutral start mechanism

Maintainability

- Good access to service parts

Comfortable cab

- New air conditioner
- Operability is improved
- Complete interior
- Pressurizing function

New APC

- Large size liquid crystal display
- Touch screen control
- Rear and side view monitor are available

Displays Outstanding Power in Heavy-Duty Operation

1 Mounts a new reliable US EPA Tier 4 and EU Stage IV compliant Daimler (Mercedes-Benz) OM936LA (MTU 6R1000) engine.



Selective Catalytic Reduction (SCR) system

The SCR system cuts the NOx (nitrogen oxides), PM (particulate matter) and NMHC (non-methane hydrocarbon). The emission control is compliant with Stage IV and Tier4.

EGR (Exhaust Gas Recirculation) system

The large capacity water-cooled EGR cooler suppresses the NOx.

2 **Selective Catalytic Reduction (SCR) system**

The SCR system provides chemical reaction between Urea and NOx in emission. This reaction generates Nitrogen and Water which are friendly to environment.

The large capacity DEF (Desel Exhaust Fluid) tank

DEF replenishment is every 1 time per 3 times of fuel replenishment (subject to working condition).

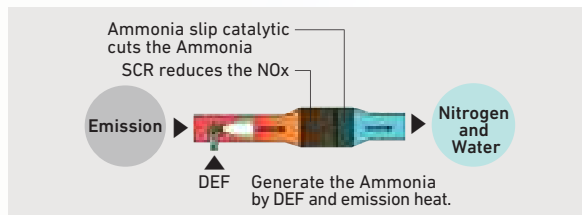

NOx is decreased by **80%**

Great improvement made on the cycle time

Implementation of dramatic improvement on work efficiency due to optimization of the hydraulic circuit also enhances its usability. At E-mode, it is also possible to operate at a speed equal to or faster than the P-mode of the previous model. (HD1430V)

Cycle time improved by **33%** during a 90° swing

Digging force

Max. arm digging forcece...159kN
at high power.....166kN

Max. bucket digging force...224kN
at high power.....235kN

Working range

Max. digging radius...11,210mm
Max. digging depth...7,450mm
Max. digging height...10,420mm

3 Further reduction in fuel consumption, thanks to the improvement on energy efficiency of the hydraulic circuit.

New control valve

Operability enhancement resulting from the improvement of internal structure of the new control valve. Hydraulic fluid flow has been made efficient with the newly adopted bucket flow circuit. Moreover, great reduction of pressure loss because of the adoption of the large diameter spool. It also contributes to reduction in fuel consumption.



Pressure loss is greatly reduced due to the optimization of the hydraulic piping.

Minimization of energy loss, pressure loss reduction, optimization of every hydraulic piping all thanks to the increment of the piping diameter in front of the bucket and arm cylinder.



Reduction of fuel consumption by **17%** (In comparison to the HD1430V)

Reputable undercarriage

Further improvements made on reliability, hence a travelling frame of the previous model with a solid-track record, has been adopted. Improvement made on durability for the track roller and carrier roller

- The travelling frame under cover is now a standard feature.
- Reinforcement made to the cover plates' thickness of the traveling motors' by 2.2 times. In addition, an enhanced square bar as a newly added feature (optional).
- Reinforcement of the traveling frame's internal structure by 1.4 times.
- Enhanced track guard reinforcement making bending difficulty.

Safer Cab with Various Features

The KATO original cab is durable and of smart design. The cab is compliant with ROPS safety standard (ISO 12117-2). It secures the safety and protection of the operator from roll-over over accident. The cab is also compliant with ISO 10262 (Top guard level I) and protects the operator from falling objects.

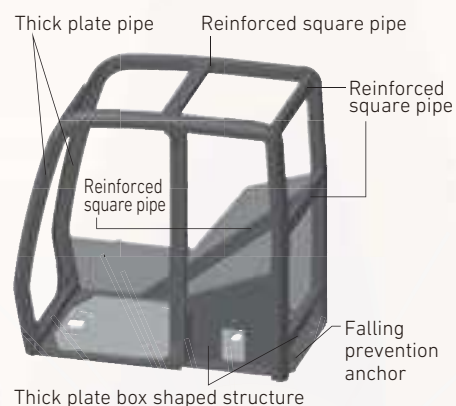

Window and rise up wiper

The large size right window and the rise up wiper secure excellent view. The wiper is storable to the right pillar.



Polycarbonate door window

Polycarbonate prevents the cracking that arise from scattering stones. Hard coating secures high resistance to yellowing or scratching of the surface.



Handrail and step

To prevent falling accident, the handrail has been provided to the upper structure. The large size anti-slip step enables operator to access the upper structure safer.



Safety lock lever

The new electronic control lock mechanism enhances safety and prevents misoperation. It locks the hydraulic circuit in case the console is jumped up. The engine start operation is active only when the lever is applied to lock position.

Other safe features

- Rear view camera
- Side view camera (option)
- Emergency engine stop switch
- Emergency escape hammer
- Seat belt
- Fire wall
- Fan guard
- Retractable side mirror
- LED working light (option)
- Fire extinguisher (option)



Best Comfort and High Efficiency



Heat & cold insulation box

It is capable of storing 6 drink bottles (500mL).



Rear stowage space

It is capable of storing objects such as 2L size drink bottle.



New foot rest arrangement

The foot rest has been relocated to optimum position. Replacement of the floor mat has now become easier.



Drink holder

Soft material is used for the drink holder. Various arrangements are available.



New operation lever

Operation switches are arranged on the bottom and top of the lever knob. The lever knob is easy to control.



Cab pressurization

It prevents dust by enhancing the airtightness.

Air conditioner

- Air volume is increased by 26%
- Paper type filter

Other cab features

- Seat suspension with large size shock absorber
- Luggage space
- Helmet hook
- AM/FM radio with 2 speakers
- USB port (option)
- 12V electric port (option)
- Ash tray (option)
- Sun visor (option)
- Rain visor (option)
- Transparent roof hatch (option)



New APC for Smart Operation



Visibility

Large and high resolution display

The display is 7 inch in size and the IPS liquid crystal display provides high quality image.

Safety

Rear view camera for standard feature

Operator is able to confirm rear and side view through dual view display (side view camera is an option).



It indicates rear and side view at the same time.

Operability Touch screen control is available for all operations.



Mode selection

Pull-down menu enables operator to confirm all modes on the display at once.



Alarm message

The display indicates various alarms. It also indicates the DEF aqueous fluid replenishing timing.



Air conditioner

The air conditioner operation is available on the display.



Various information

Operator is able to set up display various information such as maintenance information.

High Performance and Superior Maintenance

Cab maintenance space

It is possible to replace the filter for the air conditioner and replenish the washer fluid from the cab maintenance space, located outside of the cab.

Battery disconnect switch

It is capable to shut down the battery completely into a non-operation state. The maintenance for electronic devices becomes safer.

Fuel pre-filter

The integrated water separator is mounted towards the rear right of the body, providing easier to access.

Reinforced swing motor type and reduction gear lubrication pipe

Durability enhancement as a result of mounting a better swing motor, consisting of a reinforced shaft. Improved maintainability with the newly adopted elongated hydraulic pipe supply port and remote type discharge port.

Large capacity tool box

In addition to storage of tools and the grease pump, the large capacity tool box is also capable of stowing a 20L polyethylene tank, a grease cartridge (that can hold 20 grease containers), all together at once.

LED light (option)

The LED lights have been provided to the cab, right-front and the boom.

New pre-cleaner

Labor saving during maintenance as it is equipped with automatic dust cleaning mechanism.

Cooling system

Facilitates for easier cleaning with the new parallel arrangement of the radiator, oil-cooler and intercooler.

Expansion tank

Improvement in engine air bleeding and cooling performance. The expansion tank is located on top of the radiator.

Air cleaner equipped with a double element

The engine durability is improved by capturing particles like dust in the air intake. In addition, the element replacement intervals are extended.

Technical Specifications

ENGINE

Model..... Daimler OM936LA (MTU 6R1000)
 Type..... 4-cycle, water-cooled, in-line, direct injection with turbocharged
 Number of cylinders..... 6
 Bore & Stroke..... 110 mm × 135 mm
 Total displacement..... 7.70 L
 Rated output..... 205kW/1,950min⁻¹ (ISO 14396)
 182kW/1,950min⁻¹ (ISO 9249 Net)
 Max. torque..... 1,150N·m/1,200min⁻¹ (ISO 14396)
 1,120N·m/1,200min⁻¹ (ISO 9249 Net)
 Compression ratio..... 17.6:1
 Cooling system..... Pressurized coolant circulated by coolant pump with the thermostat and expansion tank
 Lubrication system..... Pressurized oil fed by a gear pump through full-flow and by-pass cartridge filter
 Starter..... Electric, 24V-5.5kW
 Generator..... Alternator, 28V-100A
 Air cleaner..... Dry type double elements air filter with intake stack mounted pre-cleaner

HYDRAULIC SYSTEM

Main pumps..... 2×Variable piston pumps
 Max. discharge flow..... 2×310L/min
 Max. discharge pressure..... 31.4MPa
 Max. discharge pressure (high power)..... 32.9MPa
 Oil filtration..... Full-flow filter with replaceable element, a pilot line filter and suction strainer
 Control valves..... 5+4 section multiple control valves (with one free service circuit)
 Pilot pump..... Gear type
 Oil cooler..... Finned tube, forced ventilation
 Pressure relief valves..... Primary and secondary on each circuit

SWING SYSTEM

Drive..... Axial piston motor with shockless valve and reduction gear
 Brake..... A hydraulic brake that locks automatically when the swing control lever is in the neutral position and a mechanical parking brake which is applied when the safety lock lever is pulled backwards, the engine is turned off or the swing control lever is in the neutral position.
 Lubrication..... Completely housed and grease bathed
 Max. swing speed..... 10.0min⁻¹

TRAVEL SYSTEM

Drive..... 2×Axial piston motor and reduction gear (independent for each side)
 Brakes..... Mechanical parking brakes operated interlocking travel levers neutral position
 Track shoes..... 48 each side
 51 each side (LC)
 Track adjustment..... Grease cylinders with recoil springs
 Lubrication..... Sealed-for-life rollers and front idlers with floating seals
 Travel speed..... High 0~5.8km/h
 Low 0~3.9km/h
 Gradeability..... 70% (35°)
 Max. drawbar pull..... 270kN

DIGGING FORCE (ISO 6015)

Bucket digging force..... 224kN at high power
 235kN
 Arm (2.93m) digging force..... 159kN at high power
 166kN

SERVICE DATA

Fuel tank..... 645 L
 Cooling system..... 36 L
 Engine oil..... 29.5 L
 DEF tank
 Capacity..... 95 L
 Replenishment..... 79 L
 Track drives..... 2×4.0 L
 Hydraulic oil tank
 Level..... 200 L
 System..... 405 L

CAB&CONTROLS

Type..... All weather sound suppressed, cab mounted on 6 point viscous mounting
 Right hand levers..... Controls the boom & bucket
 Inner right hand lever (with foot pedal)..... Controls the right hand track
 Inner left hand lever (with foot pedal)..... Controls the left hand track
 Left hand levers..... Controls the arm & swing
 Pilot controls..... Travel, boom, arm, bucket and swing
 Engine throttle..... Electric "Accel dial"
 Meters & gauges..... Hour meter, water temperature DEF and fuel level
 Working lights..... Provided on the boom left side and tool-box front side
 Lubrication chart..... Inside of the tool-box lid

Quick Selection of Working Modes.....
P: Professional mode for the experienced operator. Established both power and good response
A: All-round multipurpose Mode for all application from precision work to heavy duty work by stroke of operation levers
E: ECO Mode for economical works

AIR CONDITIONER

Air conditioner gas contains fluorinated greenhouse gases.
 Industrial designation..... HFC-134a
 Quantity..... 1.0kg
 CO₂ equivalent..... 1.43ton
 Global warming potential (GWP)..... 1430

Dimensions

HD1430-7

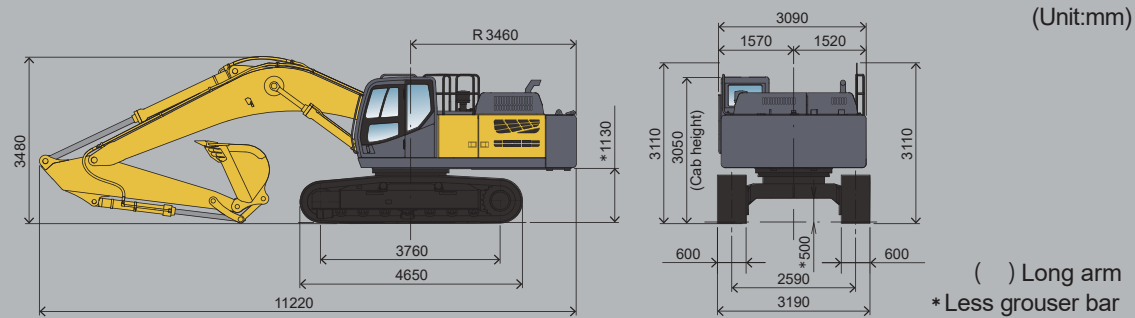

HD1430LC-7

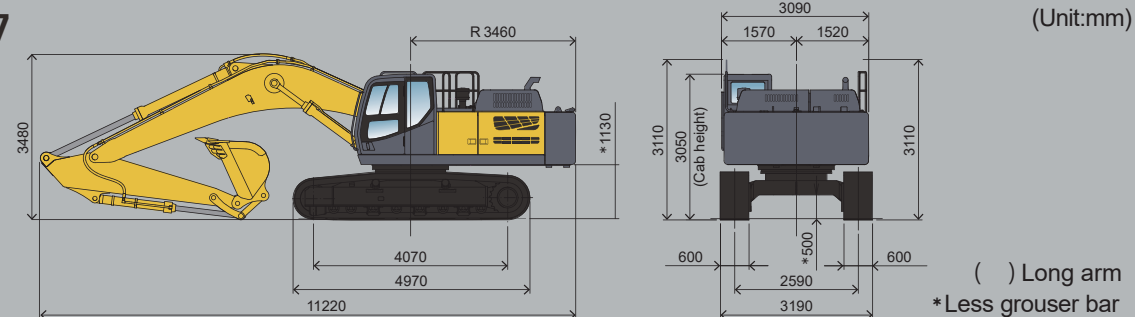

Working Ranges



HD1430-7
 Specs

Standard backhoe

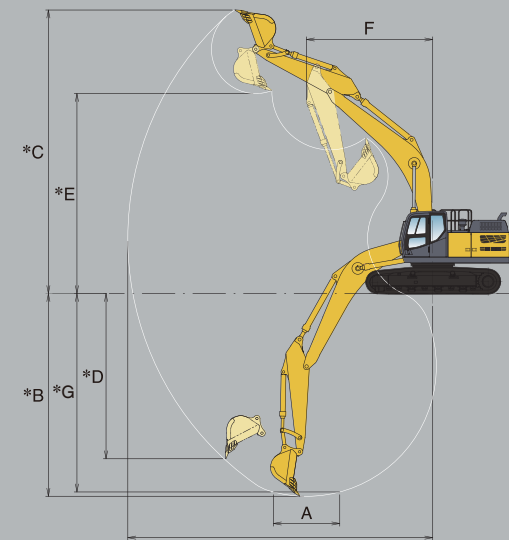

Unit : mm *Less grouser bar

Range	Arm	Standard boom		Bracket on boom for small swing radius (option)	
		Standard arm 3.14m	Long arm 4.14m	Standard arm 3.14m	Long arm 4.14m
A : Maximum digging radius		11,210	12,100	11,210	12,100
* B : Maximum digging depth		7,450	8,450	5,820	6,820
* C : Maximum digging height		10,420	10,720	12,300	12,910
* D : Maximum vertical wall		6,070	6,970	4,890	5,870
* E : Maximum dumping height		7,350	7,660	9,060	9,670
F : Minimum swing radius		4,460	4,680	2,730	2,760
* G : Maximum digging depth at 2,440mm (8ft) floor length		7,290	8,320	5,660	6,690

Lifting Capacities

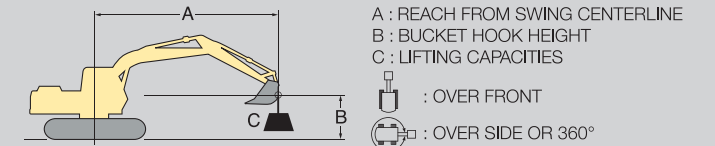

HD1430-7 BOOM: 6.48 m, ARM: 3.14 m, BUCKET: 1.4m³ (1140kg), SHOE WIDTH: 600mm, COUNTERWEIGHT: 6,400kg Unit: kg

LIFT POINT HEIGHT B(m)	LIFT POINT RADIUS A(m)								AT MAXIMUM LIFT POINT RADIUS						
	1.50	3.00	4.50	6.00	7.50	9.00	10.50	12.00	RADIUS (m)	RADIUS (m)	RADIUS (m)				
7.50									*4930	*4930	*3980	*3980	7.97		
6.00									*5150	*5150	*2970	*2970	*2750	9.03	
4.50									*5780	*5780	*5520	4130	*2770	9.56	
3.00									*6640	5460	5810	3970	*2910	9.83	
1.50									*7540	5150	5630	3800	*3160	9.86	
0.00									*7320	4910	5490	3670	*3580	9.65	
-1.50	*9280	*9280	*8150	*8150	*6890	*6890	*8610	6890	7320	4910	5490	3670	*3580	9.20	
-3.00	*8340	*8340	*6970	*6970	*6870	*6870	*8240	6700	7180	4780	5430	3620	*4280	8.45	
-4.50	*7150	*7150	*6810	*6810	*7350	*7350	*9700	6860					7640	7.33	
-6.00					*8620	*8620							*8840	8140	5.58

HD1430LC-7 BOOM: 6.48 m, ARM: 3.14 m, BUCKET: 1.4m³ (1140kg), SHOE WIDTH: 600mm, COUNTERWEIGHT: 6,400kg Unit: kg

LIFT POINT HEIGHT B(m)	LIFT POINT RADIUS A(m)								AT MAXIMUM LIFT POINT RADIUS						
	1.50	3.00	4.50	6.00	7.50	9.00	10.50	12.00	RADIUS (m)	RADIUS (m)	RADIUS (m)				
7.50									*4930	*4930	*3980	*3980	7.97		
6.00									*5150	*5150	*2970	*2970	*2750	9.03	
4.50									*5780	*5780	*5520	4240	*2770	9.56	
3.00									*6640	5600	*5960	4080	*2910	9.83	
1.50									*7540	5290	*6470	3910	*3160	9.86	
0.00									*8300	5050	6350	3780	*3580	9.65	
-1.50	*9280	*9280	*8150	*8150	*6890	*6890	*8610	7070	*8300	5050	6350	3780	*3580	9.20	
-3.00	*8340	*8340	*6970	*6970	*6870	*6870	*8240	6880	8330	4920	6290	3730	*4280	8.45	
-4.50	*7150	*7150	*6810	*6810	*7350	*7350	*9700	7040					*5550	7.33	
-6.00					*8620	*8620							*8840	8340	5.58

NOTE : 1. Lifting capacities are based on ISO 10567.
 2. Lifting capacities shown do not exceed 87% of machine hydraulic capacity or 75% of minimum tipping load.
 3. Capacities marked with an asterisk (*) are limited by hydraulic capacities.
 4. Lifting capacities are based on machine standing on firm, uniform supporting surface. User must make allowances for job conditions such as soft or uneven ground.
 5. Lifting capacities shown should not be exceeded. Weight of all lifting accessories must be deducted from the above lifting capacities.
 6. Capacities apply only to the machine as originally manufactured and equipped by KATO WORKS CO., LTD.
 7. The operator should be fully acquainted with the instruction manual before operating the machine.