

2019 EN



WWW.ATLASGMBH.COM

ATLAS SINCE 1919 GROUP





ATLAS

SINCE 1919

GROUP

CONTENTS

ATLAS GROUP	4
WHEELED EXCAVATORS	9
CRAWLER EXCAVATORS	17
MATERIAL HANDLING MACHINES	23
RAIL-ROAD EXCAVATORS	29
HEAVY WHEEL LOADERS	37
LOADER CRANES	43
ATLAS CRANES UK Ltd	47
ATLAS AND THE MILITARY	49
EKA SUPER COMPACT	53
TUNNELING AND MINING EQUIPMENT, SPECIAL MACHINERY	59
S20 SHAFT EXCAVATORS	67
ATLAS SPARE PARTS	71



ATLAS – CONSTRUCTION MACHINERY MANUFACTURER WITH TRADITION

From person to person

When Hinrich Weyhausen started selling construction and agricultural machinery in 1919 he discovered that the machines that his customers actually needed were not available. So he listened to them carefully and went about building the machines himself – exactly according to the requirements of the people who used his machines every day. He carried out pioneering work with a passion under the brand name of Atlas. His focus was always on the benefit of the machines. And nothing has changed for us in terms of this ideal today.



**Atlas will make you strong
with excellent products and
a comprehensive service.**



With highly motivated employees, a great deal of commitment and expertise ATLAS GmbH develops successful crane, excavator, material handling and crawler excavator technologies. Numerous customers, engineers and experts all around the globe have made their contribution. The result is robust equipment to enable you to work more effectively and safer than ever before.

As our know-how grew, so too did our dealer and service network worldwide.

We can hence guarantee – in those days and today too – that we will always be on the spot when you need us.



Atlas manufactures a wide range of equipment for the construction, railroad, material handling and infrastructure industries. You will find more information on Atlas under www.atlasgmbh.com.

CONSTRUCTION



TRANSPORT



INFRASTRUCTURE



RECYCLING



CUSTOMER SATISFACTION IS OUR PRIORITY!

WE ARE COMMITTED

to providing our customers with highest quality products and services.

QUALITY STANDARDS AND CUSTOMER SATISFACTION

are measured in terms of service performance, reliability, relevance and timeliness.

OUR COMPANY'S MISSION, GOALS AND OBJECTIVES

are directed towards ongoing process improvement as a basis for strengthening our competitive position and for improving product quality and service standards.

QUALITY STANDARDS AND CUSTOMER SATISFACTION

are measured in terms of product performance and reliability.

ATLAS

SINCE 1919

CRAWLER EXCAVATORS

Operating Weight : from 18,000 up to 40,000 kg

- 160LC
- 170LC
- 190LC
- 225LC
- 260LC
- 340LC
- 185LCsr
- 215LCsr



MATERIAL HANDLING MACHINES

Operating Weight : from 16.000 up to 59.200 kg



RAIL-ROAD EXCAVATORS

Operating Weight : from 20,000 up to 22,000 kg



- 1404ZW
- 1604ZW

- | | | |
|-------|-------|--------|
| 160MH | 300MH | 160MHE |
| 180MH | 350MH | 250MHE |
| 200MH | 400MH | 350MHE |
| 250MH | 520MH | |
| 270MH | 550MH | |

HEAVY WHEEL LOADERS

ATLAS Heavy Wheel Loaders combine compact dimensions with impressive productivity for outstanding value. Their strengths really come to the fore in applications including earth moving, road construction, recycling, wood processing, agriculture and certain areas of the alternative energy industry.



- L160
- L210
- L260
- L310

WHEELED EXCAVATORS

Operating Weight : from 14,000 up to 23,000 kg

- 140W
- 150W
- 160W
- 160Wsr
- 165Wsr
- 175Wsr
- 180Wsr
- 190W
- 220W



G R O U P

MEDIUM CRANES

from 88 to 240 kNm



Flexible. Compact. Sensitive.

Fitted with state-of-the-art technology and as reliable as a simple lifting pulley - this is what distinguishes our cranes for trucks from 7.5

to 22 tons. Achieving the highest degree of precision through great sensitivity. Fitted with LM+ technology for increased output up to 18%.



Atlas offers cranes with optimized technology and equipment.

- Landscaping
- Delivery
- Municipalities
- Material handling
- Building material

LARGE CRANES

from 250 to 620 kNm

Load. Precision. Reach.

Do you want maximum lifting capacity and reach? Welcome to the best productivity class, especially for trucks weighing more than 24 tons. Special features include a load sensing system (optional), twin slewing gear, continuous slewing gear and a wide range of fittings such as fly jib or winches. These cranes are faster in operation than comparable cranes with the same lifting capacity.

- Building material
- Container logistics
- Lifting logistics
- Assembly work



SMALL CRANES

from 11 to 75 kNm

Lightweight. Simple. Slimline.

In operation our smallest cranes are the greatest: low dead weight, easy to use and quick to mount. They have been specially constructed for small trucks.

- Landscaping
- Delivery
- Authorities
- Checking wells
- Building material
- Checking operation





- Factory trained
- On-going training new products
- Conversant with LOLER requirements
- ALLMI operator and Thorough Examination Trained
- Backed up by fully trained Supervisors
- 6 Monthly auditing of all field service engineers

ATLAS AND THE MILITARY



- Over 2,500 cranes and excavators supplied since 1968
- Design, manufacture, fitting, service and support direct from one source
- In-depth knowledge, advice and technical expertise from a dedicated

team

- Crane and component refurbishment from specially designed workshops
- Product excellence, performance and reliability from the industry experts
- Nationwide service and support network

EKA RECOVERY – SuperCompact

EKA Limited was formed to specifically focus in the area of military recovery equipment and has continued to concentrate in this specialized sector for over 30 years.



EKA personnel have long-term experience working within the heavy truck and military recovery sectors and that knowledge, of both equipment and task, is integrated into the equipment EKA design and supply.



With more than 50 years of experience in tunnelling attachments and special machines technology, SCHAEFF has the specialist knowledge to deliver high quality machines for a wide range of applications.

- Tunnel heading machines
- Tunnel excavators
- Mucking and loading machines
- Rail ballast loading machines
- Electric and special excavators
- Special machines
- Hydraulic rotary cutters

SHAFT EXCAVATOR



The excavator unit is fitted with a first slewing gear which can be turned 2x90° and a second swing assembly which can be turned the full 360° to enable precise positioning to empty the dipper in the transport bucket area.



**CYLINDERS,
ATTACHMENTS,
STEEL FABRICATIONS,
MACHINING, PAINTING,
BLASTING**

ATLAS

SINCE 1919

WHEELED EXCAVATORS

9 MODELS · 14-23 TONS



STABLE. STRONG. STEADY.

HIGH PERFORMANCE



Excellent view



Intelligent load independent hydraulics



Comfort



Safety light for climbing

Improved cooling



Always secured



Optimized undercarriage



- Dynamic performance
- Low fuel consumption
- Lower exhaust emissions

Better visibility



Easily accessible AdBlue® tank



Quiet and efficient exhaust system



Perfect weight distribution



Large slew-ring

HIGH PERFORMANCE



- Light
- Articulate
- Robust
- High lifting capacity



Easy to service

New extended undercarriage (2.6 m) for stable driving



Hose and cylinder protection (Option)



Hydraulic axle lock



Brake hoses protection

THE ENGINE

TIER4 FINAL ENGINE



GOOD FOR THE ENVIRONMENT

- DEUTZ TCD 4.1/6.1 and CUMMINS QSB 6.7 meet the EU Stage IV/US EPA Tier 4 Final emissions standards.
- DPF filter for particle reduction (Deutz engine).
- SCR filter for reducing NOx.

GOOD FOR YOUR WORK AND COMFORT

- Fuel saving.
- Lower emissions - better performance.
- Compact design.
- Long service life.
- Particularly quiet engine.
- Low maintenance costs.
- Fast and inexpensive service.

INTELLIGENT HYDRAULICS FOR MORE PRODUCTIVITY

BREAK PROTECTION

- Optimized pipes and hoses layout.
- Smaller installation size.
- Reduced noise levels.
- Sensitive lower function.

COST EFFECTIVENESS

- Power at the right time.
- Fast working cycles.
- Large bucket capacity.
- Maximum breakout and ripping forces.
- Operator friendly.



INFORMATION AT EXACTLY THE RIGHT TIME



- **AEM SYSTEM**
- **MULTI-FUNCTION SCREEN**
- **PRE-PROGRAMMED MODES:
FINE, ECO AND POWER MODE**
- **360° PANORAMA VIEW CAMERA (OPTION)**
- **CRUISE CONTROL.**

TELEMATIC FOR SAFETY AND SERVICE

- **ANTI-THEFT PROTECTION**
- **PRODUCTIVITY AND PERFORMANCE**
- **ACCURATE CALCULATION**
- **COMPLETE OVERVIEW**
- **ACCESSIBLE ANYWHERE**
- **ENGINE AND EXCAVATOR PARAMETERS**
- **LIVE GPS TRACKING**
- **FUEL CONSUMPTION AND SERVICE INTERVALS**
- **AND MORE ...**



PRODUCT RANGE

		Operating weight (kg)	Engine power kW (HP)	Max. Digging depth (m)
	MODEL			
	140W	13 800 - 15 700	90 (121)	5.5
	150W	15 600 - 17 300	95 (130)	5.7
	160W	16 000 - 17 800	105 (143)	5.7
	160Wsr	16 000 - 19 500	95 (130)	6.7
	165Wsr	16 200 - 18 500	105 (143)	5.65
	175Wsr	16 100 - 18 600	115 (156)	5.65
	180Wsr	17 500 - 21 000	115 (156)	7.1
	190W	18 900 - 20 800	116 (158)	6.71
	220W	22 000 - 22 600	129 (175)	6.5

ATLAS

SINCE 1919

CRAWLER EXCAVATORS

8 MODELS - 18-40 TONS



ROBUST. PRECISE. EFFICIENT.

EXCELLENT CONTROL & VISIBILITY

PARTICULARLY EFFECTIVE BOOM DESIGN

Extremely light and enormously
robust booms

ELEVATABLE LIFT OR VARIO CABIN OR FIXED LEVEL CABIN FOR BEST VISIBILITY

FUNCTIONAL AND SPACIOUS CAB

The Design is adapted to your needs.

STANDARD AIR CLIMATE CONTROL

DURABLE AND COMFORTABLE

New Atlas driver seat

INTELLIGENT HYDRAULICS

For more productivity and perfect controls:

- Our intelligent hydraulics management enables load-independent overlapping of working motions.
- A sensitive hydraulics system perfectly attuned to all work processes.

IDEAL WEIGHT DISTRIBUTION

- Fast turnover and fatigue-free work.
- Perfect weight adjustment by a transversely installed engine.
- Through the optimal positioning of the upper structure, we achieve very high lifting capacities and very good digging depths.

NEW TIER 4 FINAL

Dynamic performance, low fuel consumption, lower exhaust emissions and little need for servicing – ready for the most extreme work conditions.



Atlas builds its crawler excavators especially for the hardest working sites. The result is the robust machines to withstand the worst possible working conditions.

High-strength materials, high productivity and cost-effectiveness – save time and money in the future.

NEW QUIETER EXHAUST SYSTEM

Covering EU Stage IV / US EPA Tier 4



ALWAYS SECURED – New camera system with integrated TFT monitor



IMPROVED AIR INTAKE

to optimize engine work.



NEW ATTRACTIVE COUNTERWEIGHT

Design and better weight distribution



LIFT AND VARIO CABINE – SYSTEMS

to ensure perfect visibility and safety.

THE ENGINE

TIER 4 FINAL ENGINE

**RANGE OF PERFORMANCE
DEPENDING ON THE CRAWLER
EXCAVATOR: 80—180KW AT 1800 RPM 4
OR 6 CYLINDER DIESEL ENGINES**

GOOD FOR THE ENVIRONMENT:

• DEUTZ TCD 4.1 L4, DEUTZ TCD 6.1 L6

All engines which meet the EU Stage IV / US EPA Tier 4 emissions standards with DVERT® particulate filter (DPF/SCR).

• CUMMINS engines:

The QSB6.7 achieves these very low emission standards by using cooled Exhaust Gas Recirculation (EGR). Both systems have been specifically developed for industrial applications delivering premium performance and durability you can depend on (DOC/SCR).



GOOD FOR YOUR WORK:

- Water-cooled 6-cylinder diesel engines with turbocharging, intercooler and cooled external exhaust gas recirculation.
- Engine and exhaust aftertreatment (EAT) are adapted to an optimum efficiency of the total system and therefore ensure minimum fuel and total running costs.
- The powerful DEUTZ Common Rail (DCR®) injection system and the electronic engine control (EMR 4) with intelligent link to the drive management ensure optimum engine performance at low fuel consumption.
- Improved CUMMINS High Pressure Common Rail (HPCR) fuel system enabling cleaner and more efficient combustion resulting in an up to 5 percent better fuel efficiency without compromising performance.
- Enormous power density at very low engine speeds and compact design.
- In summary for Tier 4 Stage: Fuel savings of up and more than 10 percent compared with Tier 3 Stage, combined with lowered exhaust emissions and better performance.



POWER



GOOD FOR YOUR COMFORT AND FOR YOUR NERVES

- Long oil change intervals and easy changing of the engine fluids reduce the running costs and increase the availability of the machinery.
- Engine controller that supplies the display with operating and service data.
- Particularly quiet engine.
- Efficient spare parts logistics and easy installation.

Lowest Cost Of Operation - Reduced maintenance, long service intervals and the best fuel efficiency of any engine in its class add up to superior lifetime value.

TURBO-CHARGED ENGINES PROVIDE FAST AND POWERFUL MOTIONS, FAST CYCLE TIMES AND DYNAMIC POWER DEVELOPMENT

SO EASY

The engine offers extremely smooth running characteristics. Automatic idle is a standard feature.

Cold start assist gets you moving, even after the hardest frost.

SO QUIET













The engine is fitted with protection against vibrations and thus decoupled from the revolving superstructure.

SO CLEAN

In their field the engines already meet all requirements of the EU Stage IV / Tier 4.



PRODUCT RANGE

	MODEL	Operating weight (kg) 	Engine power kW (HP) 	Max. dig depth (m) 
	160LC	18,000	95 (130)	7.02
	170LC	19,000	95 (130)	6.26
	190LC	19,900	105 (143)	6.40
	225LC	23,900	116 (158)	6.35
	260LC	26,600	129 (175)	7.69
	340LC	35,500	180 (245)	7.77
	185LCsr	19,000	105 (143)	5.65
	215LCsr	21,800	115 (156)	7.15

ATLAS

SINCE 1919

MATERIAL HANDLING MACHINES

13 MODELS - 16-59 TONS



STRONG. RELIABLE. MULTIFUNCTIONAL.

EXCELLENT CONTROL & VISIBILITY

Functional and spacious cab



The design is adapted to your needs.



- Dynamic performance
- Low fuel consumption
- Lower exhaust emissions



Decreased noise level



Quiet and efficient exhaust system



Perfect weight distribution



Practical accessibility



Cylinder protection

Elevatable - LIFT or VARIO cabin or fixed level cabine for best visibility



Optimized kinematics for the boom



Optimized arms hydraulics



Easily accessible AdBlue® tank



Hydraulic axle lock



Extended wheelbase

GREEN POWER IS HERE



Electric engine

total power:

- 170 kW (350MHE)
- 125 kW (250MHE)
- No CO₂ emissions
- Low noise
- Low generation of heat

Control cabinet for E-Drive



Engine hood designed for better visibility



Cable reel



Lockable master switch



... and will save you money

Perfect control



The proven attachment tools
can be used



Compressor unit
for electric heating
and climate control
system



PRODUCT RANGE

	MODEL	Operating weight (kg) 	Engine power kW (HP) 	Max. Range (m) 
	160MH	17,500	90 (112)	8.4
	180MH	19,200	95 (130)	10.1
	200MH	20,000	105 (143)	10.1
	250MH	25,000	129 (175)	12.65
	270MH	27,000	129 (175)	14.8
	300MH	31,500	129 (175)	14.4
	350MH	36,000	180 (245)	18.2
	400MH	41,000	180 (245)	18.1
	520MH	57,000	230 (313)	21.9
	550MH	59,000	230 (313)	21.9
	160MHE	17,500	90 (112)	8.4
	250MHE	25,000	125	12.65
	350MHE	36,000	170	18.20

ATLAS

SINCE 1919

RAIL-ROAD EXCAVATORS

FROM 17 TO 23 TONS



SAFE. POWERFUL. RELIABLE.

UNCOMPROMISINGLY BUILT FOR HIGH PERFORMANCE

Atlas builds its wheeled excavators especially for the hardest construction sites. The result is the robust machines to withstand the worst possible working conditions.

High-strength materials, high productivity and cost-effectiveness — save time and money for future.

New quieter exhaust system covering new Euro 4 STAGE / US EPA TIER 4 Final emission standards with a sealed diesel particle filter.

New Tier 4 Final engines — lower exhaust emissions

New attractive counterweight design and better weight distribution

Always secured - new camera system with 5/6' interior monitor.

New "LED" rear lights for better visibility and safety



Intelligent hydraulics for more productivity and perfect controls. Load-independent overlapping of working motions.



Standard air-climate control system



Improved air intake to optimize engine's work



Particularly effective boom design — extremely light and enormously robust booms

Ideal weight distribution, fatigue-free work and fast turnover

Functional and spacious cab design adapted to your needs

TECHNICAL SPECIFICATION 1404 ZW

MAIN DIMENSIONS

Base machine A41.5 – with 4 outriggers

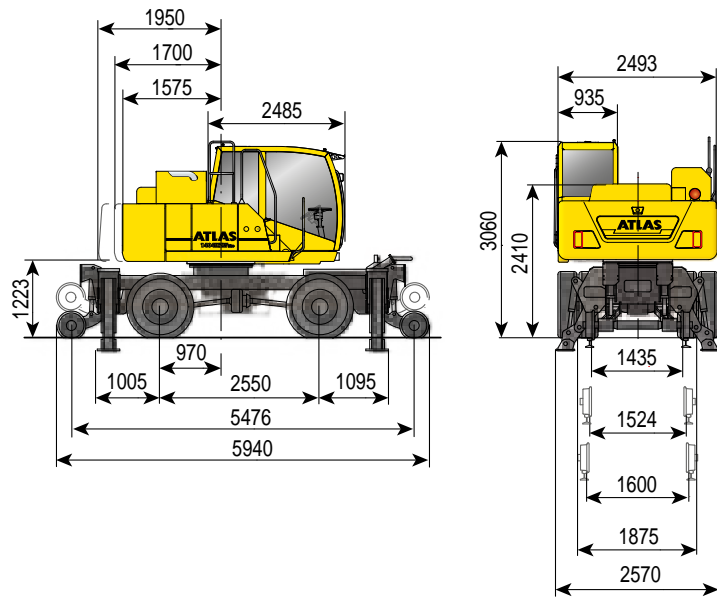

TRAVEL CONFIGURATION WITH GRAB

Base machine A41.4 – without outriggers

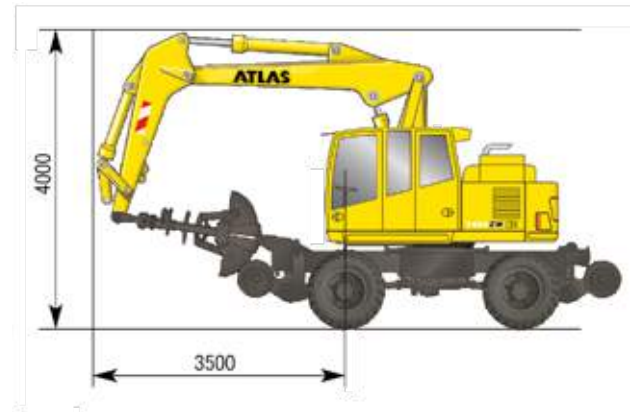

WORKING EQUIPMENT:

Base machine		Weight/kg	Standard equipment
A41.4	Rail-Road hydraulic excavator 1404 ZW, without outriggers, tailswing 1575 mm	13600	<ul style="list-style-type: none"> Maintenance point for filtration system
A41.5	Rail-Road hydraulic excavator 1404 ZW, with 4 outriggers, tailswing 1575 mm	16000	<ul style="list-style-type: none"> Hydraulic system for grab and grab rotation function
Additional and special equipment			
B41.20	Heavy counterweight (5.3 t), tailswing 1575 mm	800	<ul style="list-style-type: none"> Tank indicator
	Heavy counterweight (4.9 t), tailswing 1700 mm	400	<ul style="list-style-type: none"> Battery main switch in negative lead.
	Heavy counterweight (5.3 t), tailswing 1700 mm	800	<ul style="list-style-type: none"> "Travel" function via foot control
B41.39	Additional hydraulic unit for variable boom cylinder	20	<ul style="list-style-type: none"> Accumulator for emergency lowering of boom system
B41.23	Two man fully glazed cab	300	<ul style="list-style-type: none"> Sliding window in cab door
Base section of arm and boom			
C53.41P	Base arm with two lift cylinders and an internally mounted operating cylinder	1090	<ul style="list-style-type: none"> Windshield washer system
C53.46	Boom with articulating cylinder only for base arm C53.41P	930	<ul style="list-style-type: none"> Central lubrication (Option)
Sticks			
D41.22	Rail-road excavator stick, working length 2200 mm	490	<ul style="list-style-type: none"> Tilt and height adjustable steering column
Bucket tipping cylinder			
F53.1	Bucket tipping cylinder with reversing linkage	165	<ul style="list-style-type: none"> Radio pre-installation
Rail guidance			
<p>CARSY (Computer assisted rail contact pressure system). Automatic system for regulating and monitoring the force of the rail guide wheels. The required pressures are automatically set, continuously monitored and adjusted if necessary. Depending on the pre-selected operating condition, each separate guidance bogie wheel is set to a different pressure in accordance with a prescribed schedule, locked or hydraulically trailed.</p>			<ul style="list-style-type: none"> Storage box in the cab
			<ul style="list-style-type: none"> Comfort seat with armrests and lumbar support
			<ul style="list-style-type: none"> Toolbox on chassis
			<ul style="list-style-type: none"> Sealed pivot points in the base section of the boom
			<ul style="list-style-type: none"> Boom and stick with 50 hour maintenance intervals
			<ul style="list-style-type: none"> Securing lug for securing the grab during road travel
			<ul style="list-style-type: none"> Air-conditioning
			<ul style="list-style-type: none"> Air dryer for compressed air system
			<ul style="list-style-type: none"> Narrow axles for underground and suburban railways
			<ul style="list-style-type: none"> Right side camera
			<p>The front and rear bogie wheels can be independently switched to permit simple de-railing and positive crossing of rail points.</p>
			<p>Automatic self-diagnosis of the electronic system. Emergency function: de-railing is assured even in the event of a fault or complete breakdown.</p>
			<p>Track gauge 1435 mm, other widths on request.</p>

TECHNICAL SPECIFICATION 1404 ZW

ENGINE

Power rating acc. to ISO 1585	95 kW (130 HP)
Manufacturer	Deutz
Type	TCD 4.1 (Stage Tier 4 Final)
Displacement	4000 cm ³
Rotational speed	1800 rpm
Design	Turbocharger/charge-air cooling

HYDRAULIC SYSTEM

Computer controlled AWE4 system with a load limiting high performance piston pump and fuel efficient on-demand power control for sensitive, proportional and load independent ramp-up of all operational movements

- Primary and secondary protection of the hydraulic system against overload
- Suction valve for all operational functions as well as restrictors in the lift and articulating circuits
- Fine lowering and load-retaining valve in the lifting circuit.

Hydraulic system	1 x AKP
Main pump	HPR 135
Max. flow variable capacity pump	300 l/min
Max. operating pressure for operating movements	340 bar

NOISE LEVEL

Noise level* is significantly below EC limits

Ambience level (L _{WA})	98 dB (A)
Cab level (L _{PA})	73 dB (A)

*Dynamic sound level measurement according to 2000/14 EC

ELECTRICAL SYSTEM

Operating voltage	24 Volt
Cold-start heavy duty battery	2 x 100 Ah

Electrical system in compliance with StVZO (Regulations Authorizing the Use of Vehicles for Road Traffic in Germany) and European standard

BRAKES

Service brake	pneumatic-hydraulically actuated drum brake
Parking brake	pneumatically-operated spring-loaded parking brake

Emergency brake for use on rail

Max. un-braked trailer load	40 t
Max. trailer load with wagon brake	120 t

FLUID CAPACITIES

Fuel tank	190 l
Hydraulic tank	200 l
Engine oil	10 l
AdBlue® tank	10 l

CAB

Flexibly suspended • Heat absorbing extra wide windscreen for all-round vision

- Glare-free interior • Ergonomic pilot control levers • Adjustable steering column
- Lengthways adjustment of the seat independent of the control console
- Front windscreen slidable under the cab roof • Second seat for mate

Type	Atlas 935 two-man comfort cab
Overall length	2130 mm
Width	935 mm

SLEWING MECHANISM

Slewing motor	axial piston motor with priority valve
Slewing gear	planetary reduction
Slewing brake*	multi-disc brake

Drive via an internally toothed slewing ring

Slewing speed	8.5 rpm
Slewing torque	37.5 kNm

* simple swinging on slopes against the incline is assured, with locking foot pedal when slewing pressure of 120 bar is exceeded.

POWER TRANSMISSION

40 t special excavator axles with planetary drives to all four wheel hubs

- All-wheel drive • Variable drive engine • Double acting travel brake valve
- Travel direction selector with steering column mounted lever or switch on pilot control lever • Steering axle with automatic oscillation lock
- Travel controls via foot pedal valve

TRAVEL SPEED

Road and rail operation

Creep speed	max. 1.0 km/hour
Off-road speed	max. 5.0 km/hour
Highway speed	max. 20 km/hour

Rail guidance, track gauge 1435 mm, other widths on request

TIRES

8 x	10.00 - 20
-----	------------

(inner tire - highway, outer tire - off highway tread pattern)

WEIGHT

Operating weight	17.0 - 20.0 t
------------------	---------------

OPERATING WEIGHTS, TAILSWING



TECHNICAL SPECIFICATION 1604 ZW

MAIN DIMENSIONS

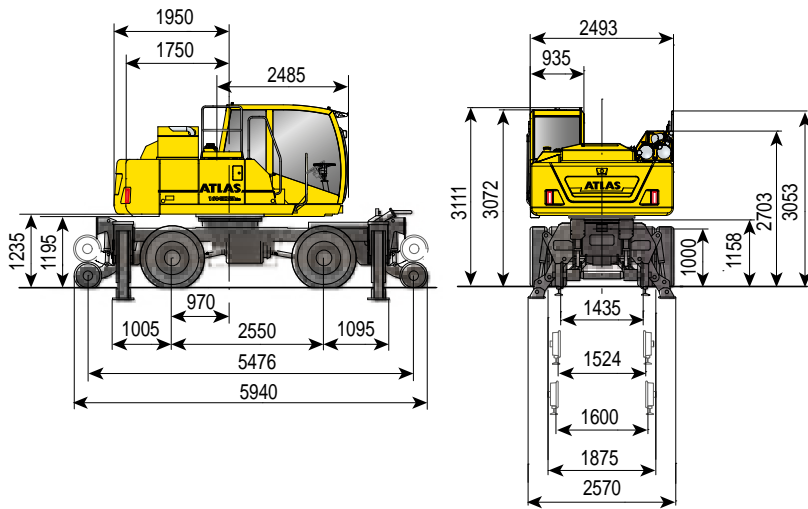

TRAVEL CONFIGURATION WITH GRAB

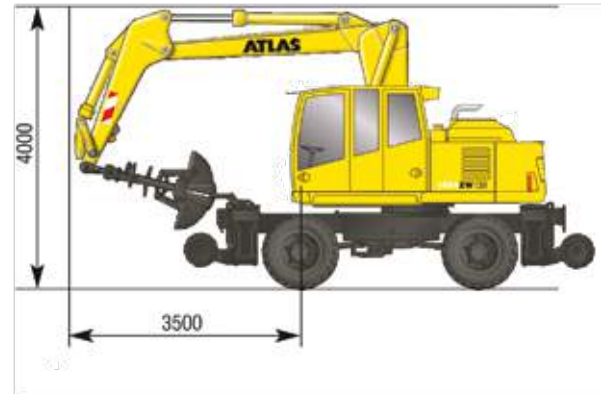

WORKING EQUIPMENT:

Base machine		Weight/kg	Standard equipment
A67.5	Rail-Road hydraulic excavator 1604 ZW, with 4 outriggers, tail swing 1750 mm	18100	<ul style="list-style-type: none"> Narrow axles for underground and suburban railways
Additional and special equipment			<ul style="list-style-type: none"> Central lubrication (Option)
B66.41	Hose-rupture safety device for lifting cylinder, overload warning device	10	<ul style="list-style-type: none"> Maintenance point for filtration system
B67.20	Counterweight, tail swing 1950 mm	0	<ul style="list-style-type: none"> Proportional Grab-rotation
B66.39	Additional hydraulic unit for variable boom cylinder	20	<ul style="list-style-type: none"> Hydraulic system for grab and grab rotation function
B41.23	Two man fully glazed cab	300	<ul style="list-style-type: none"> Tank indicator
Base section of arm and boom			<ul style="list-style-type: none"> Battery main switch in negative lead "Travel" function via foot control
C67.41P	Base arm with two lift cylinders and an internally mounted operating cylinder	1350	<ul style="list-style-type: none"> Accumulator for emergency lowering of boom system
C66.46	Boom with articulating cylinder only for base arm C67.41P, working length 3300 mm	930	<ul style="list-style-type: none"> Traction increase
Sticks			<ul style="list-style-type: none"> Sliding window in cab door Power shift transmission
D67.22	Rail-road excavator stick, working length 2240 mm	600	<ul style="list-style-type: none"> Windshield washer system Tilt and height adjustable steering column
Bucket tipping cylinder			<ul style="list-style-type: none"> Radio pre-installation
F66.1	Bucket tipping cylinder with reversing linkage	180	<ul style="list-style-type: none"> Storage box in the cab Comfort seat with armrests and lumbar support Toolbox on chassis Sealed pivot points in the base section of the boom Boom and stick with 50 hour maintenance intervals Securing lug for securing the grab during road travel Air-conditioning Air dryer for compressed air system Right side camera

TECHNICAL SPECIFICATION 1604 ZW

ENGINE

Power rating acc. to ISO 1585	115 kW (157 HP)
Manufacturer	Deutz
Type	TCD 4.1 (Stage Tier 4 Final)
Displacement	4000 cm ³
Rotational speed	1800 rpm
Design	Turbocharger/charge-air cooling

HYDRAULIC SYSTEM

Computer controlled AWE4 system with a load limiting high performance piston-pump and fuel efficient on-demand power control for sensitive, proportional and load independent ramp-up of all operational movements

- Primary and secondary protection of the hydraulic system against overload
- Suction valve for all operational functions as well as restrictors in the lift and articulating circuits
- Pipe break protection valves for lifting and articulated cylinders

Hydraulic system	1 x AKP
Main pump	HPR 210
Max. flow variable capacity pump	380 l/min
Max. operating pressure for operating movements	340 bar

NOISE LEVEL

Noise level* is significantly below EC limits

Ambience level (L _{WA})	97 dB (A)
Cab level (L _{WA})	71 dB (A)

*Dynamic sound level measurement according to 2000/14 EC

ELECTRICAL SYSTEM

Operating voltage	24 Volt
Cold-start heavy duty battery	2 x 100 Ah

Electrical system in compliance with StVZO (Regulations Authorizing the Use of Vehicles for Road Traffic in Germany) and European standard

BRAKES

Service brake	pneumatic-hydraulically actuated drum brake
Parking brake	pneumatically-operated spring-loaded parking brake

Emergency brake for use on rail

Max. un-braked trailer load	40 t
Max. trailer load with wagon brake	120 t

FLUID CAPACITIES

Fuel tank	260 l
Hydraulic tank	300 l
Engine oil	10 l
AdBlue® tank	20 l

CAB

- Flexibly suspended
- Heat absorbing extra wide windscreen for all-round vision
- Glare-free interior
- Ergonomic pilot control levers
- Adjustable steering column
- Lengthways adjustment of the seat independent of the control console
- Front windscreen stowable under the cab roof
- Second seat for mate

Type	935 two-man comfort cab
Overall length	2130 mm
Width	935 mm

SLEWING MECHANISM

Slewing motor	axial piston motor with priority valve
Slewing gear	planetary reduction
Slewing brake	multi-disc brake

Drive via an internally toothed slewing ring

Slewing speed	9 rpm
Slewing torque	59 kNm

POWER TRANSMISSION

40 t special excavator axles with planetary drives to all four wheel hubs

- All-wheel drive
- Variable drive engine
- Double acting travel brake valve
- Travel direction selector with steering column mounted lever or switch on pilot control lever
- Steering axle with automatic oscillation lock
- Travel controls via foot pedal valve
- Power shift transmission
- Traction increase

TRAVEL SPEED

Road and rail operation

Crawling speed	max. 1.3 km/hour
Off-road speed	max. 5.6 km/hour
Highway speed	max. 20 km/hour

Rail guidance, track gauge 1435 mm, other widths on request

TIRES

8 x	10.00 - 20
-----	------------

(inner tyre - highway, outer tyre - off highway tread pattern)

WEIGHT

Operating weight	21.0—23.0 t
------------------	-------------



SAFE. POWERFUL. RELIABLE.

**Building on technology –
High-tech excavator for use on rails.**

THE RIGHT CHOICE EVERY TIME

ATLAS rail-road excavators were especially developed for use on rails and combine optimum mobile excavator technology with the most up-to-date know-how for rail use. This is your guarantee for top performance, even with difficult track conditions. We were the first to put an excavator on rails in 1965.

We were market and technology leaders in this field back then and still are today. As the sole world-wide supplier, we offer the computer assisted rail contact pressure system (CARSY).

We are the sole manufacturer in Europe of rail-road, short tailswing excavators with a swing radius of less than 2000 mm in combination with the approval of German Federal Railways. We can offer any chassis configuration to fit any rail network for our world-wide customers.



As option available:
Friction Drive System available
for 1404 ZW with track width
1000 and 1435 mm.

ATLAS – CONSTRUCTION MACHINERY MANUFACTURER WITH TRADITION

Take advantage of our many years of know-how and experience for your application: on rail, alongside the track and mounted on the railway wagon.

ATLAS SINCE 1919

PRODUCT RANGE

HEAVY WHEEL LOADERS



PRODUCTIVE AND POWERFUL

Load sensing hydraulic system (LUDV) delivers hydraulic power only when needed.

Single-lever pilot control with integrated direction of travel switch for simple directional changes.

Outstanding overhead loading height, large dumping widths and powerful tear-out and lifting forces.

Powerful loading technology with ATLAS SP-kinematics combining the advantages of parallel and Z-kinematics.

Continuously variable travelling speed up to 40Km/h for reduced journey times.



Additional 'Versa Steer' steering mode as standard for optimal control and reduced operator fatigue.

ROPS/FOPS cab and fully glazed second door.

Ergonomic cab with excellent rear visibility and climate control system for operator comfort.

High-performance cooling system with reversible fan for greater productivity.

Short tail with transverse engine installation provides optimum stability and excellent rear visibility.

High performance engines with impressive power development even at low speeds.

Wide-opening hood for easy service access.

Low wear multi-disc brakes integrated in the axles providing protection from dirt and damage.

High-performance steel chassis with outstanding ground clearance for access to the toughest job sites.

IN A CLASS OF THEIR OWN

ATLAS Heavy Wheel Loaders combine compact dimensions with impressive productivity for outstanding value. Their strengths really come to the fore in applications including earth moving, road construction, recycling, wood processing, agriculture and certain areas of the alternative energy industry.



▶ **L160**

Operating weight	9,200 kg
Engine power	74.5 kW (102 HP)
Bucket capacity	1.5 - 3.0 m ³



▶ **L210**

Operating weight	12,500 kg
Engine power	119 kW (162 HP)
Bucket capacity	2.0 - 3.5 m ³



▶ **L260**

Operating weight	14,400 kg
Engine power	128 kW (174 HP)
Bucket capacity	2.5 - 4.5 m ³



▶ **L310**

Operating weight	17,600 kg
Engine power	149 kW (203 HP)
Bucket capacity	3.0 - 5.0 m ³



HIGHER FURTHER

The ATLAS loader arm lift mechanism makes all the difference: high volume performance, fast work cycles, precise operation and enormous power development in all work movements.

With optional extensions, you can attain even more impressive lifting heights while significantly expanding the action radius.





ROBUST CONSTRUCTION

The 3-point suspension of the bucket consists of 80 mm bucket hinge pins. To protect material while working, the bucket anchor points are located directly on the lifting frame. Sealed bearing points on the lifting frame/bucket make for increased service life.

MAXIMUM DUMP HEIGHT

Extended cab lift mechanisms are available as an option in a 0.65 and 1.25 meter size.

What this means for you:

-  Large bucket opening and ideal bucket angle make for productive filling.
-  High tear-out/rack-back force over the entire lifting range, especially in the highest position – important for buckets with hydraulic clamping device.
-  Excellent view of attachments.
-  Suspension point quick-change device: Many different work attachments can be used.

USE WITH PALLET FORK

The ATLAS lift mechanism is perfectly suited for use with pallet fork thanks to 100% parallel guidance. Depending on the model, up to 3.94 m stacking height and cargo loads of up to 9 tonnes can be transported.

ALWAYS THE RIGHT TOOL

With the right tool tool, a ATLAS wheeled loader can handle a wide variety of work.

The choice is yours

- ▶ Universal bucket (4-in-1)
- ▶ Grab bucket (compost bucket)
- ▶ High-tilt bucket
- ▶ Fork carrier
- ▶ Quick-change device
- ▶ Timber grab

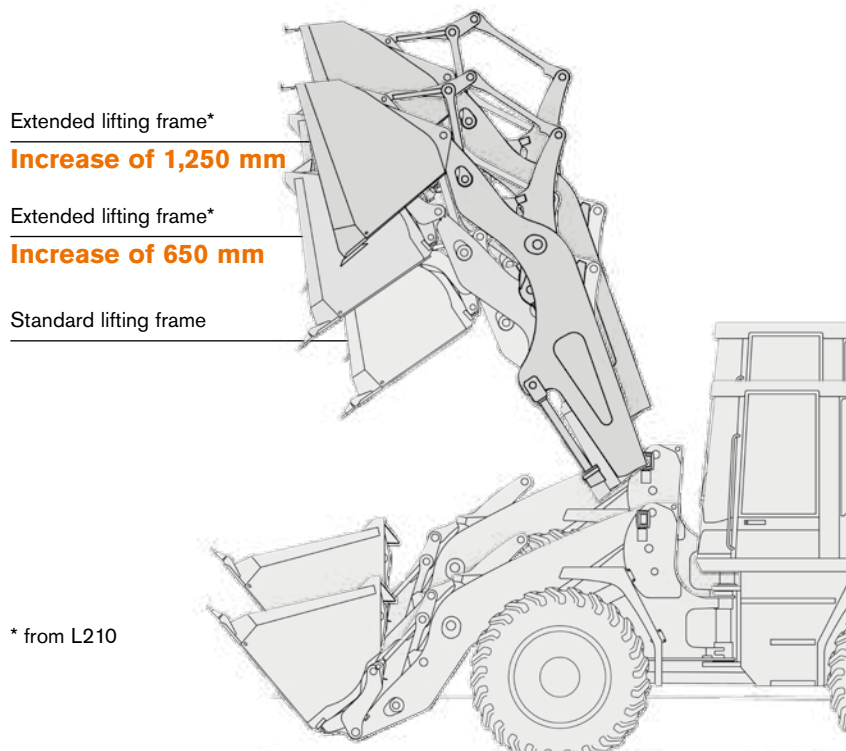

* from L210

DELMENHORST

Powerful Sensitive Robust





Lifting was never so easy



The product portfolio

Small cranes – from 11 to 75 kNm Lightweight. Simple. Slimline.

In operation our smallest cranes are the greatest: w dead weight, easy to use and quick to mount. They have been specially constructed for small trucks.

Great flexibility in use

- Landscaping
- Authorities
- Building material
- Delivery
- Checking wells
- Checking operation

Medium cranes – from 88 to 240 kNm Flexible. Compact. Sensitive.

Fitted with state-of-the-art technology and as reliable as a simple lifting pulley - this is what distinguishes our cranes for trucks from 7.5 to 22 tons. Achieving the highest degree of precision through great sensitivity. Fitted with LM+ technology for increased output up to 18%. Atlas offers cranes with optimized technology and equipment.

A class in itself – in operation too

- Landscaping
- Authorities
- Building material
- Delivery
- Material handling



The right crane for any task and for any truck: we will supply you with the full line from 11 to 620 kNm. We will design your individual crane together with you. 55 basic models and 300 different booms, up to 22 metres of hydraulic reach with 9 hydraulic extensions are available to help you.



**Large cranes – from 250 to 620 kNm
Load. Precision. Reach.**

Do you want maximum lifting capacity and reach? Welcome to the best productivity class, especially for trucks weighing more than 24 tons. Special features include a load sensing system (optional), twin slewing gear, continuous slewing gear and a wide range of fittings such as fly jib or winches. These cranes are faster in operation than comparable cranes with the same lifting capacity.

Where strength counts

- Building material
- Container logistics
- Lifting logistics
- Assembly work





Equipped with the best ideas

Folding cranes: space-saving miracles

Folded up to save space, they are mounted between a truck cab and superstructure or at the back of a truck to leave enough space on the loading area, even for bulky goods.

V-cranes: faster than any others

The special jib combination makes for more efficiency: rotating movements are faster than linear ones.

T-cranes: it couldn't be easier

For special application and with the right technology - this crane is a very uncomplicated operating tool.

(e)LMplus: a lot more lifting capacity

Gives a loaded crane a whole lot more capacity.
Up to an extra 18% load moment possible.

E-Series: the extra class

An Atlas milestone which opened up new possibilities for working with cranes.
Effective synthesis between technology, convenience, safety and efficient electronics system.



ONE CALL FOR ALL OUR CUSTOMER NEEDS 08444 99 66 88

- CALL MONITORING FACILITY
- INTERNET BASED SYSTEM
- CALLS RECORDED
- 24 HOUR TELEPHONE COVER
- DEDICATED CONTROLLERS
- OPTION TO LEAVE MESSAGE*
*30 minute max response time



DEDICATED CONTROLLERS FOR BREAKDOWNS (REACTIVE TEAM)

- Focus on breakdowns – getting engineers to site quickly
- Keeping customers updated during process

DEDICATED CONTRACT CONTROLLERS FOR CONTRACTS (PROACTIVE TEAM)

- Manage services dates
- Follow up on reported work (estimate/complete)
- Make sure LOLER regulations are adhered to.
- Keep customers advised of wear patterns.



FULLY EQUIPPED

- ON BOARD GENERATING SYSTEM
- LAPTOP COMPUTER FOR DIAGNOSTICS
- COMPREHENSIVE VAN STOCK
- TRACKING FACILITY
- SATELLITE NAVIGATION



SERVICE – ENGINEERS TRAINING

- FACTORY TRAINED
- ON-GOING TRAINING NEW PRODUCTS
- CONVERSANT WITH LOLER REQUIREMENTS
- ALLMI OPERATOR AND THOROUGH EXAMINATION TRAINED
- BACKED UP BY FULLY TRAINED SUPERVISORS.
- 6 MONTHLY AUDITING OF ALL FIELD SERVICE ENGINEERS

HEALTH & SAFETY – WORKING AT HEIGHT

- 2005 WORKING AT HEIGHT REGULATIONS FOCUS COMPANIES TO LOOK HOW DAY TO DAY WORK IS CARRIED OUT.
- WE LOOKED AT VARIOUS WAYS TO REDUCE THE RISK OF WORKING ON THE BACK OF A VEHICLE.
- ATLAS WORKED FOR 12 MONTHS TO COME UP WITH A FINAL DESIGN OF PLATFORM.
- PROJECT INCLUDED INVESTMENT IN NEW VANS TO ALLOW FITMENT OF PLATFORM.



ATLAS[®]
SINCE 1919

CRANES UK LTD

SERVING THE MILITARY FOR
MORE THAN 40 YEARS



AVAILABLE & COST EFFECTIVE

WWW.ATLASGMBH.COM



A PROVEN TRACK RECORD SINCE 1968

- OVER 2,500 CRANES AND EXCAVATORS SUPPLIED SINCE 1968
- DESIGN, MANUFACTURE, FITTING, SERVICE AND SUPPORT DIRECT FROM ONE SOURCE
- IN-DEPTH KNOWLEDGE, ADVICE AND TECHNICAL EXPERTISE FROM A DEDICATED TEAM
- CRANE AND COMPONENT REFURBISHMENT FROM SPECIALLY DESIGNED WORKSHOPS
- PRODUCT EXCELLENCE, PERFORMANCE AND RELIABILITY FROM THE INDUSTRY EXPERTS
- NATIONWIDE SERVICE AND SUPPORT NETWORK



REFURBISHMENT AND REPAIR



From complete cranes to power packs, rams, valve blocks and other major hydraulic components, Atlas provides a comprehensive refurbishment service using skilled engineers based in its UK workshops. The company is currently undertaking a number of refurbishment contracts as part of its total solution for the military.

The resource is designed to maximise the working life and financial viability of all Atlas cranes supplied to this all-important sector.

TRUCK MOUNTED LOADER (TML)



The Truck Mounted Loader (TML) contract is typical of the way in which Atlas works with the MOD's Preferred vehicle suppliers. This contract called for the supply of 104 cranes which started to come into service in September 2009.

- Scope: 33 x TML 240.2e A2 and 71 SLDT 105.2 A1L cranes
- Chassis: Iveco 6x6 Trakker
- Lifting capacity: Up to 6 tonnes
- Controls: Included on vehicle, plus remote control pack
- Expected life span: 17 years

▪ Potential uses:

- Loading of pallets on to MGB trailers
- Boats on to cradles
- Lifting of concrete slabs
- Splitting BR90 tank bridges for inspection, building and replacement panels
- ISO container handling

CRANE AND EXCAVATOR SHOWCASE



Foden Recovery 6500EA12/1



CRARRV unit with 6000M8 crane



BR90 with 5003M5 crane



Atlas 140W excavator



MAN Recovery unit with 600.2 crane



SLDT(P) with 165M1 crane



Folded 165M1 crane fitted to SLDT(P)



Camouflaged CRARRV with 6000M8 crane

SuperCompact | The rear that support the front



EKA



EKA Recovery – **SuperCompact**

In any organisation today the availability and economic use of resource is paramount.

To achieve those aims, the selection of equipment and systems to manage valuable resources is of considerable value in the strategic aims of industrial corporations and equally, if not more importantly, in defence planning and operations.

With the above précis in mind, the EKA philosophy in approaching the design of their equipment is to consider the current and long term operational requirements of supporting military vehicles, in order that our Recovery Systems maximize ARM requirements.

EKA Limited was formed to specifically focus in the area of military recovery equipment and has continued to concentrate in this specialized sector for over 30 years. EKA personnel

have long-term experience working within the heavy truck and military recovery sectors and that knowledge, of both equipment and task, is integrated into the equipment EKA design and supply.

Using a combination of in-house designed equipment and high-quality bought-in components (which incorporate specific EKA design requirements) the latest EKA recovery system SuperCompact is being supplied to MAN ERF as part of the major Support Vehicle programme for the UK MoD.

The SuperCompact is the third generation of EKA Recovery systems to be supplied to the UK MoD, and is featured in this publication installed on the MAN SX45 8x8 military chassis.



Fig. 1

SuperCompact

Fig 1 | EKA SuperCompact Recovery System on MAN SX 45.

Fig 3 | Rear suspend tow. Saxon APC.

Fig 2 | Front suspend tow. System on MAN SX 45.

Fig 4 | Rear suspend tow. MAN 6 tonne Cargo during System integration trials.



Fig. 2



Fig. 3



Fig. 4



Fig. 5

SuperCompact

Fig 5 | SuperCompact with 'swing-away' towing pintle deployed. Demonstrated towing Warrior on Hollebhone system.

Fig 6 | Side over side recovery on Bedford 4 tonne. SuperCompact using crane and main recovery winch.

Fig 7 | Front suspend tow. Foden EKA 'Compact'.



Fig. 6



Fig. 7

Fig 8 | Front suspend tow.
MAN 6 tonne Cargo during
System integration trials.

Fig 9 | Front suspend tow.
MAN 9 tonne Cargo during
System integration trials.

Fig 10 | Front suspend tow.
Unipower BR90 using
Unibeam attachment.



Fig. 8



Fig. 9



Fig.10



SuperCompact

All illustrations and specifications contained within this brochure are based on the latest product information available at time of publication. EKA Limited reserves the right to make chan-

ges, without notice, to any equipment or specifications. For any further information or enquiries, please call 01753 889818 or visit www.ekalimited.com

PRODUCT RANGE



SCHAEFF

Produced by KAEUBLE GmbH



TUNNELLING EQUIPMENT

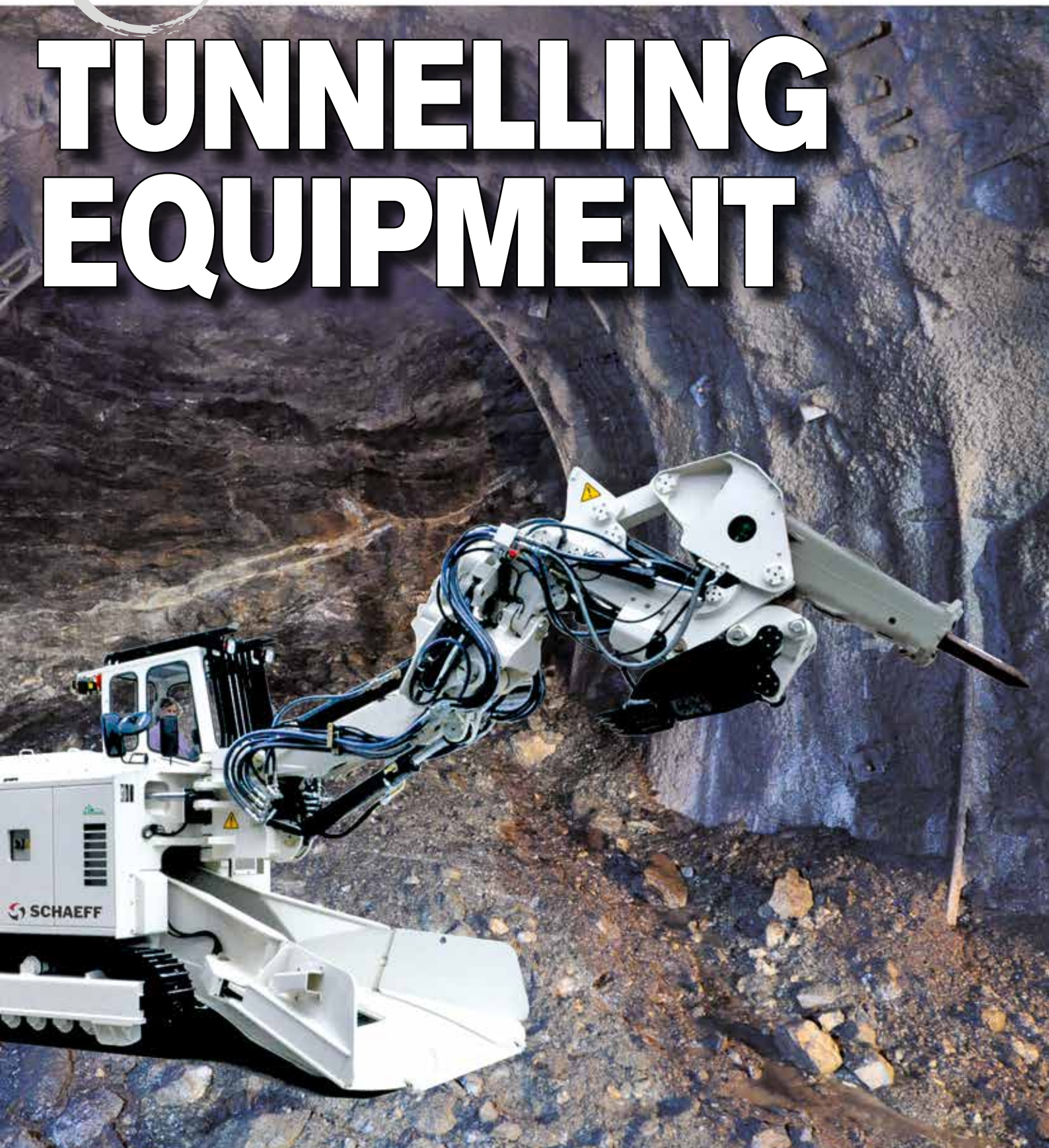

BACK AT THE FOREFRONT OF THE INDUSTRY

TUNNEL EXCAVATORS AND HEADING MACHINES

Make major progress with the extremely durable and productive Schaeff tunnel excavators, tunnel heading and loading machines. Perfect for small to medium-sized tunnel cross sections, enabling you to operate efficiently in soft to medium-hard rock or when loading excavated material that has been blasted.

With many decades of experience and specialist knowledge, we have the expertise to adapt our machines to different cross sections and geological conditions.

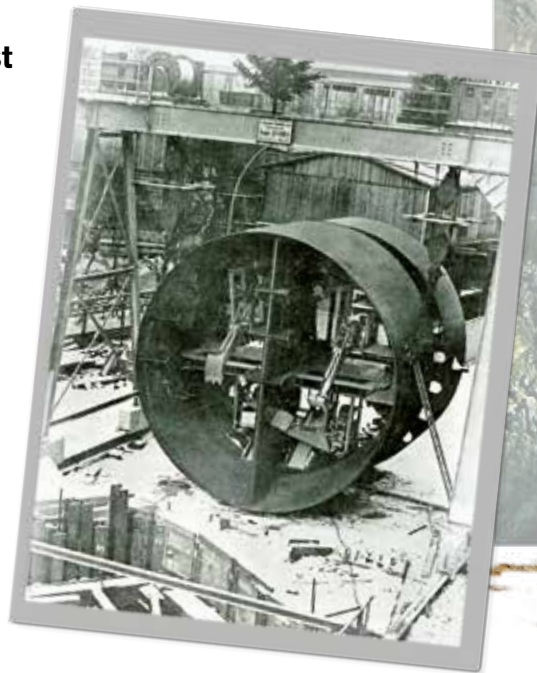

SPECIAL MACHINES

If you have a special application, Schaeff can help with custom solutions based on standard Schaeff excavators and wheeled loaders. To meet your requirements, these machines can be equipped with special work tools, drill mountings, lifting platforms, remote control, or electric drive.





MAKING A BREAKTHROUGH

With more than 50 years of experience in tunnelling attachments and special machines technology, Schaeff has the specialist knowledge to deliver high quality machines for a wide range of applications.

TUNNEL HEADING MACHINES



The patented on board hammer/bucket combination enables tools to be changed quickly saving you time and money.

MUCKING AND LOADING MACHINES



In use worldwide as high speed loading machines in soft to extreme hard and abrasive stone, as mucking machines in typical blasting operations or for scaling the tunnel face and for invert cleaning.

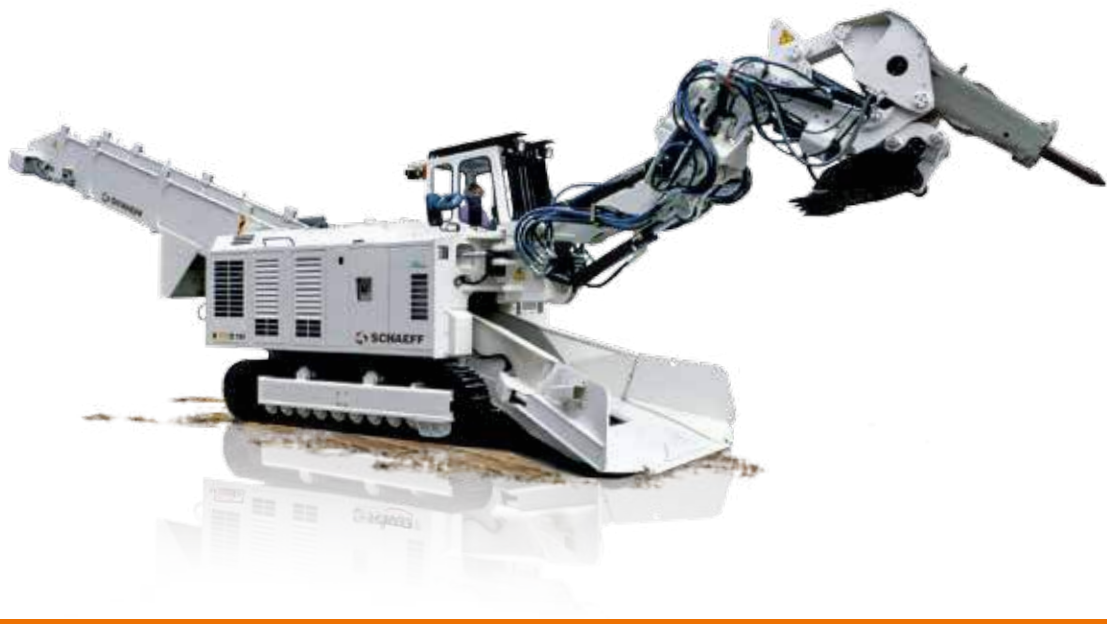

TUNNEL EXCAVATORS



With its compact design, the Schaeff TE210 is well suited for use in medium-sized cross-sections.

RAIL BALLAST LOADING MACHINES



Years of experience in the development of high performance ballast loading machines for reconstructing railway track foundations.



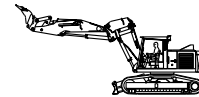

TUNNEL EXCAVATORS



Type		TE210	TE210 E
Recommended excavation cross section	m ²	25 - 60	25 - 60
Machine width	mm	2700	2700
Engine power	kW	Diesel 165	Electric 132
Travelling speed, max.	km/h	5.0	5.0
Rock breaker/attachment weight	kg	1400	1400
Gross machine weight, approx.	t	28 - 32	28 - 32
Cable reel, capacity	m	60	60

SPECIAL MACHINES

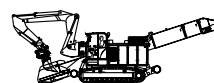

Type		ITC312-VL	TC48 E	TC16 Twin Drive
Machine width	mm	2410	1860	990 - 1340
Conveyor width	mm	800	-	-
Diesel drive power	kW	200	-	13
Electric drive power (400 V)	kW	-	22	11
Travelling speed, max.	km/h	5.0	2.9	2.4
Loading capacity up to	m ³ /min	3 - 4	-	-
Rock breaker/attachment weight	kg	700	300	-
Gross machine weight, approx.	t	36	5.3	1.9
Cable reel, capacity	m	-	30	15

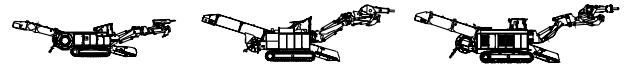

HAMMER TUNNELLING MACHINES



Type		ITC120 F2	ITC312 H6	ITC320 V45
Recommended excavation cross section	m ²	10 - 20	15 - 30	20 - 50
Machine width	mm	1900	2400	2700
Conveyor width	mm	620	800	800
Diesel drive power	kW	74	165	224
Electric drive power (400 V)	kW	55	90	160
Travelling speed, max.	km/h	3.5	5.0	3.1
Loading capacity up to	m ³ /min	1 - 2	2 - 3	2 - 3
Rock breaker/attachment weight	kg	850	1500	2600
Gross machine weight, approx.	t	25	38	50

TUNNEL HEADING MACHINES



Type		ITC120 F1 / ITC120 F3	ITC312 H1
Recommended excavation cross section	m ²	9 - 20	12 - 30
Machine width	mm	1900	2400
Conveyor width	mm	620	800
Diesel drive power	kW	74	165
Electric drive power (400 V)	kW	55	90
Travelling speed, max.	km/h	3.5	5.0
Loading capacity up to	m ³ /min	1 - 2	2 - 3
Rock breaker/attachment weight	kg	600	1000
Gross machine weight, approx.	t	24	36

TUNNEL LOADING MACHINES



Type		ITC120 F4	ITC312 H3	ITC312-SL
Recommended excavation cross section	m ²	9 - 20	12 - 30	18 - 50
Machine width	mm	1900	2400	2750
Conveyor width	mm	620	800	1000
Diesel drive power	kW	74	165	165
Electric drive power (400 V)	kW	55	90	110
Travelling speed, max.	km/h	3.5	5.0	4.8
Loading capacity up to	m ³ /min	2 - 3	3 - 5	5 - 12
Rock breaker/attachment weight	kg	600	1000	1000
Gross machine weight, approx.	t	21	35	40

Standard data – deviations in terms of equipment packages and/or country standards are possible.





SCHAEFF

Produced by KAEUBLE GmbH



S20

SHAFT EXCAVATOR



GENERAL

The excavator unit is fitted with a first slewing gear which can be turned $2 \times 90^\circ$ and a second swing assembly which can be turned the full 360° to enable precise positioning to empty the dipper in the transport bucket area.

An operator controls the excavator unit from the cab.

OPERATING DATA

Operating weight	approx. 6800 kg
Total width	2040 mm
Max. reach	7550 mm
Max. digging depth	7750 mm
Ripping force in accordance with DIN 24086	47.5 kN
Breakout force in accordance with DIN 24086	64.5 kN

HYDRAULIC SYSTEM

Working hydraulics

Axial piston displacement pump with flow adjustment and load sensing control (not included in scope of supply)

Delivery rate: max. 190 l/min at input

Operating pressure: max. 250 bar

Actuation

Hydraulic pilot-operated excavator valves for all functions.

Hydraulic cylinders

Dual-action work cylinders, partially with end-position damping

Swing drive 1

Swing system with 2 hydraulic cylinders via slewing ring

Swing area: $\pm 90^\circ$ resp. $\pm 80^\circ$ in operation mode

Swing drive 2

Hydrostatic with two-stage planetary gear and drive pinion on the inner-toothed sprocketed wheel of the slewing ring

Swing area: 360°

Swing: 0 - 8 U/min

BRAKES

Swing brake

Automatically active spring-type multi-disk brake as parking brake

The hydrostatic slewing gear also functions as a wear-free slewing brake

SUPPLIED ATTACHMENTS

Hydraulic hammer

Hydraulic cutter unit

Rock bucket



DIGGING ARC

View drawn without cabin

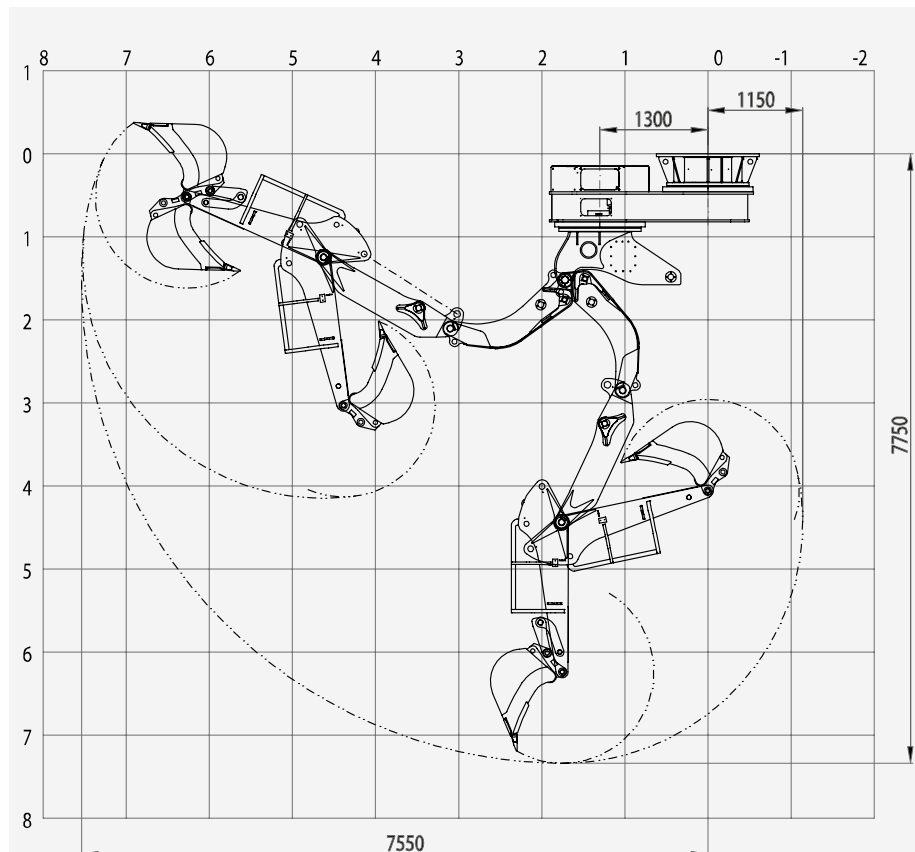



ATLAS PARTS

KRAN- & BAGGER-ERSATZTEILE

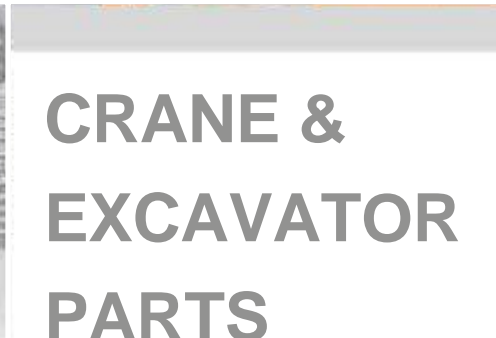
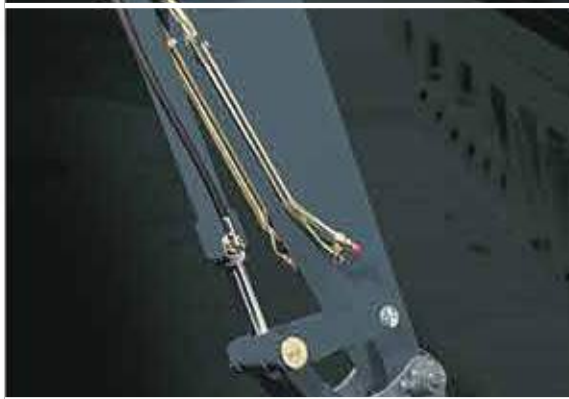

CRANE &
EXCAVATOR
PARTS



WWW.SPSGMBH.COM

CRANES & EXCAVATORS PARTS



“IT TAKES EXCELLENT SERVICE TO MAKE AN EXCELLENT PRODUCT PERFECT”

and that exactly is the service SPS provides by prompt delivery of spare parts for the maintenance and repair of your ATLAS machines.

More than 30,000 different spare parts for ATLAS excavators and cranes are kept in stock on 5,600m² of warehouse space and we service machines over 60 years old.

In case your responsible distributor does not have the required spare part in stock, we deliver 94% of all orders within 24 hours from our central warehouse. We guarantee same-day shipment in Germany if the order is placed by 16:30h, by 16:00h within Europe.

You live outside the EU? In that case we guarantee shipment on the same day if you order by 15:00h.

UNIQUE – THE ATLAS DEALER NETWORK

With many ATLAS dealers our cooperation goes way back almost to our invention of the hydraulic excavator. Our authorized dealers have at their disposal the expertise, service stations and technicians, who will visit you at your premises if necessary, and keep the most common spare parts in stock on-site. You will find an authorized ATLAS dealer also close to your location. Just click “dealer search” on www.spsgmbh.com, enter your postal area code, and within the dealer network with 135 support points in Germany you will quickly find your ATLAS-contact nearby.





WE ARE COMMITTED TO PROVIDING OUR CUSTOMERS WITH HIGHEST QUALITY PRODUCTS AND SERVICES.



OUR COMPANY'S MISSION,

goals and objectives are directed towards ongoing process improvement as a basis for strengthening our competitive position and for improving product quality and service standards. Quality standards and customer satisfaction will be measured in terms of product performance and reliability.







GANDERKESEE FACTORY

Atlas GmbH
Atlasstraße 6
D-27777 Ganderkesee,
Germany

Tel.: +49 (0) 4222 954 0
Fax: +49 (0) 4222 954 220
E-mail: info@atlasgmbh.com
www.atlasgmbh.com



VECHTA FACTORY

Atlas GmbH
Theodor-Heuss-Str. 3
D-49377 Vechta
Germany

T: +49 (0) 4441 954 0
F: +49 (0) 4441 954 299
E-mail: info@atlasgmbh.com
www.atlasgmbh.com



DELMENHORST FACTORY

Atlas GmbH
Stedinger Straße 324
D-27751 Delmenhorst
Germany

T: +49 (0) 4221 49 10
F: +49 (0) 4221 49 14 43
E-mail: info@atlasgmbh.com
www.atlasgmbh.com



**ATLAS CRANES UK LTD
NATIONAL SALES & SERVICE FACILITY**

Wharfedale Road,
Euroway Trading Est.
Bradford, England BD4 6SL
United Kingdom

T: +44 8444 99 66 88
F: +44 1274 65 37 85
E-mail: atlasuk@atlasgmbh.com
www.atlas-cranes.co.uk
www.atlasgmbh.com



**ATLAS SPARE PARTS GMBH
CRANE & EXCAVATORS PARTS**

Atlasstraße 6
D-27777 Ganderkesee,
Germany

Tel.: +49 4222 954 0
E-mail: info@spsgmbh.com
www.SPSGmbH.com

