

100
ATLAS 1919 - 2019

ATLAS
SINCE 1919

**STABLE.
STRONG.
STEADY.**

-  23 - 25 t
-  129 kW (175 hp)
-  10.25 - 12.65 m



MATERIAL HANDLING MACHINE 250MH

WWW.ATLASGMBH.COM

TECHNICAL SPECIFICATION 250MH

Technical Specification

ENGINE

Power according to ISO 9249.....	129 kW (175 HP)	Cylinder capacity	6700 cm ³	Air filter	Dry air filter
RPM	1800/min	Number of cylinders	6	Battery	2 x 12 V / 100 Ah
Make.....	Cummins QSB 6.7 (Tier 4F)	Borehole/lift.....	101/126	Alternator	24 V / 70 A
Design.....	Turbocharger / intercooler	Cooling system	Water-cooled	Starter.....	24 V / 3.2 kW

HYDRAULIC SYSTEM

• Load limit-controlled high-performance piston pump	• Suction valves for all work functions	• 2 additional circuits for additional consumer loads possible
• 7 standard consumer loads in one control block	• Load-retaining and fine-drop valve in lifting circuit	• Max. oil flow
• Sensitive, proportional, independent control	• Pump flow control	• Max. operating pressure
• Primary and secondary protection against overload	• Grab and grab-rotating function	• Operating modes: 3 pre-programmed modes (Fine, Eco, Power)
	• Pipe-break protection valves for lifting cylinders	• Proportional grab turning

SWING ASSEMBLY

• Swing motor:	Axial piston motor with priority valve	• Max. swing speed
• Swing gear:	Planetary transmission	• Swing torque
• Swing brakes:	Automatic multidisc brake	

TRACTION DRIVE AND BRAKES

• Variable displacement motor	• Maximum speed	• Max. gradeability
• Power-shift transmission	• Terrain speed	• Dual circuit brake system
• Double-acting brake valve	• Crawling speed	• Parking brake
• Driving direction pre-selection via switch in joystick	• Tractive force	

UNDERCARRIAGE

• 40 t special excavator axles	• Steering axle with automatic oscillating axle blocking	• 8 tyres
--------------------------------	--	-----------------

FILL CAPACITIES

• Fuel tank	• Engine oil	• Hydraulics system
• Cooling system	• Hydraulic tank	• AdBlue® tank.....

DRIVER'S CAB

• Meets latest safety standards	CONTROL:	CLIMATE CONTROL:
• Extra large entry zone	• Ergonomic joysticks	• Air conditioning with Climatronic
• Spacious leg room	• Slim steering column, height and tilt adjustable	• Very good air distribution through optimally arranged nozzles
• Excellent circumferential visibility	• Clear and concise arrangement of control switches	
• Preparation for radio installation with mute function		SOUND LEVELS:
	MONITORING:	• ISO6396 (L _{pA}) in driver's cab
DRIVER'S SEAT:	• Operating data display screen	• 2000/14EG (L _{wA}) ambience level
• Air-cushioned comfort seat (optional seat heating)	• Automatic system for monitoring, warning and storage of data	
• Arm rests and lumbar support		
• Seat adjustable separately from console		

WORKING EQUIPMENT 250MH

Working Equipment

OPERATING WEIGHTS

	LOADING BOOM 6.20 m (C24.5i)	LOADING BOOM 6.20 m (C24.5i)	LOADING BOOM 6.80 m (C24.6i)	ADJUSTABLE BOOM Base arm 1.95 m (C21.41) Boom 3.83 m (C21.461)
	Stick 4.80 m (D21.15i)	Stick 4.80 m (D21.15is)	Stick 5.30 m (D21.16i)	Stick 2.65 m (D21.33)
DB / outriggers	23 t	23 t	23.4 t	23.5 t
4 outriggers	23.2 t	23.2 t	23.6 t	23.7 t

Operating weight with driver, solid rubber tyres, completely filled implement and 1.0 t for attachments and 1.4 t for lift-cab (option)

EQUIPMENT

BASIC DEVICE ATLAS 250MH

- 250MH material handler with DB* on steering axle, double outrigger support on steering axle and 2 lifting cylinders (A25.35)
- 250MH material handler with quadruple outrigger support and 2 lifting cylinders (A25.39)

*DB - Dozer blade

Standard equipment:

- Rear view security camera with 5" LCD-colour monitor

Engine:

- Automatic idle
- Diesel pre-filter
- Engine monitoring

- Seat adjustable separately from console

Mono Booms:

- Loading boom 6.20 m (C24.5i)
- Loading boom 6.80 m (C24.6i)

Hydraulics:

- Grab and grab-rotating function
- Accumulator for emergency lowering of the arm system
- Pipe break protection valves for lifting cylinders
- Overload warning device
- Cylinder end-position damping

- Heat-absorbing glass, tinted windows
- Automotive drive
- Operating data screen display
- Ready for electric cooling box
- Different options for storage, compartment for documents
- Bottle holder

Mono Sticks:

- Stick 4.80 m (D21.15is)
- Stick 4.80 m (D21.15i)
- Stick 5.30 m (D21.16i)

Equipment:

- Combined lubricating points for swing bearing and arm equipment

Adjustable boom:

- Base arm 1.95 m (C21.41)
- Boom 3.41 m (C21.46)
- Boom 3.83 m (C21.461)
- Stick 2.65 m (D21.33)

Cab:

- Air-conditioning
- Preparation for radio installation with mute function
- Slim steering column, height and tilt adjustable

Undercarriage:

- Power-shift transmission
- Wet disc brakes
- Tool box in the undercarriage

ADDITIONAL EQUIPMENT

Engine:

- Refueling pump
- Auxiliary heating
- Engine speed adjustment via potentiometer
- Cold startup assistance

Equipment:

- Automatically controlled and monitored electric central lubrication system

- Lift-Cab (to 2.50 m drive up)

- Cab elevation 1.2 m /0.6 m

- Electric cooling box

- Working lights, LED

Hydraulics:

- Hydr. adaptor kit, switch supports pairwise in front and back
- Biodegradable oil

Cab:

- Cab protection guard
- Beacon light
- Heated driver's seat
- GPS/GSM telemetric system for monitoring of operating data, consumption, position
- Radio/CD/MP3, front AUX in, USB

Undercarriage:

- Vollgummireifen

Other special equipment: see price list

ATTACHMENTS

- Clamshell grab
- Orange peel grab
- Load hook
- Load lifting magnet
- Log grab

WORKING RANGES 250MH

Working ranges Loading boom 6.20 m (C24.5i) and stick 4.80 m (D21.15i)

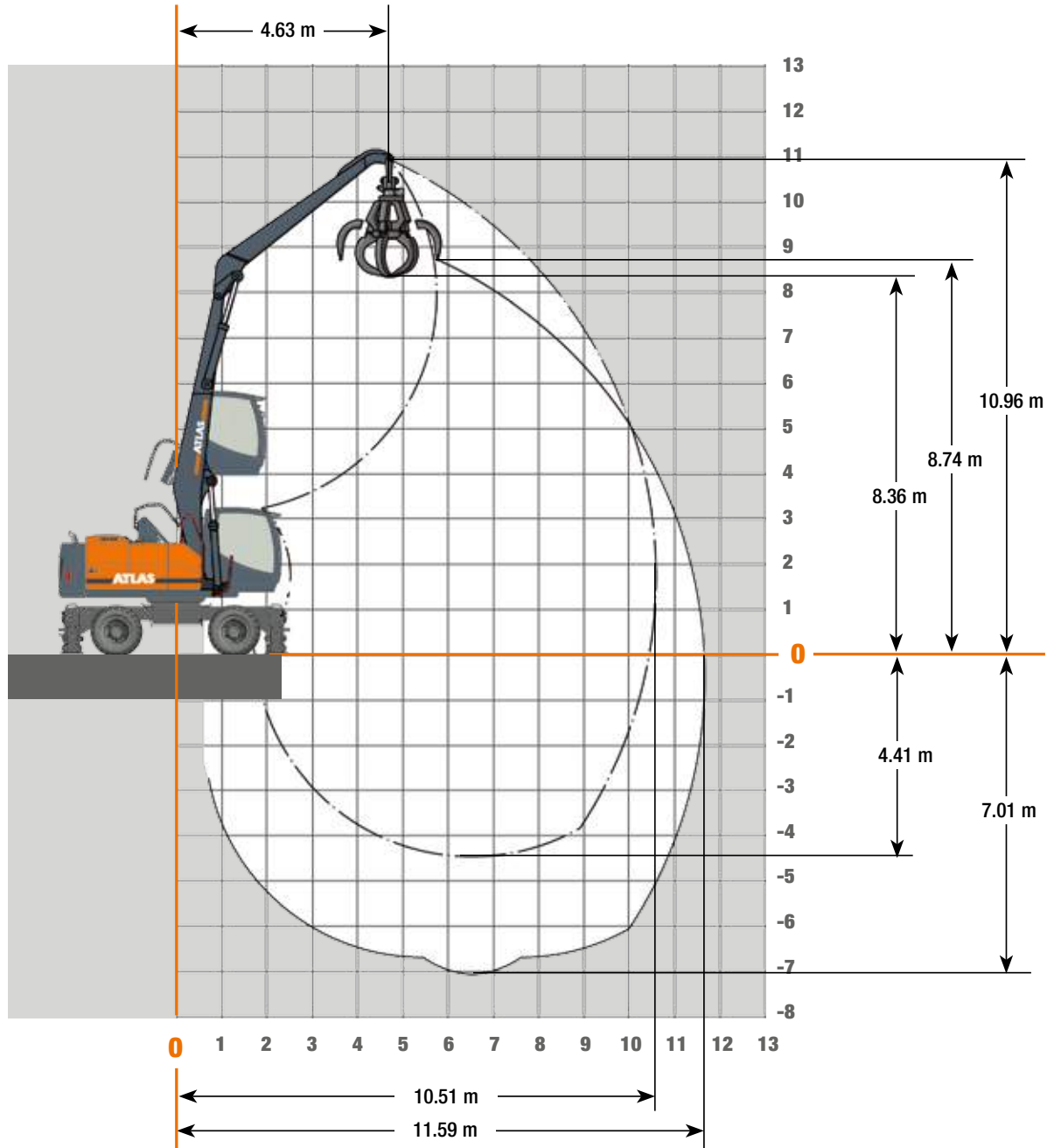

LIFTING CAPACITIES 250MH

Lifting Capacities Loading boom 6.20 m (C24.5i) and Stick 4.80 m (D21.15i)

Lifting Capacities Loading boom 6.20 m (C24.5i) with stick 4.80 m (D21.15i). Max. reach 11.60 m											
HEIGHT		3,0 m		4,5 m		6,0 m		7,5 m		9,0 m	
		FRONT	LATERAL	FRONT	LATERAL	FRONT	LATERAL	FRONT	LATERAL	FRONT	LATERAL
9.0 m	Outriggers lowered					6,2*	6,2*	5,4*	5,4*		
	Outriggers raised					5,7	4,7	3,9	3,3		
7.5 m	Outriggers lowered					6,1*	6,1*	5,4*	5,4*	4,7*	4,2
	Outriggers raised					5,7	4,7	4	3,3	3	2,4
6.0 m	Outriggers lowered					6,3*	6,3*	5,4*	5,4*	4,7*	4,2
	Outriggers raised					5,6	4,6	4	3,3	3	2,4
4.5 m	Outriggers lowered			8,4*	8,4*	6,7*	6,7*	5,6*	5,5	4,8*	4,2
	Outriggers raised			8,4*	6,9	5,4	4,4	3,9	3,2	2,9	2,4
3.0 m	Outriggers lowered	14,7*	14,7*	9,6*	9,6*	7,2*	7,2*	5,8*	5,4	4,8*	4,1
	Outriggers raised	14,7*	11,8	7,9	6,3	5,2	4,2	3,7	3	2,8	2,3
1.5 m	Outriggers lowered	2,8*	2,8*	10,4*	10,4*	7,5*	7,3	5,8*	5,2	4,7*	4
	Outriggers raised	2,8*	2,8*	7,3	5,8	4,9	3,9	3,6	2,9	2,8	2,3
0 m	Outriggers lowered			10*	10*	7,3*	7	5,6*	5,1	4,4*	3,9
	Outriggers raised			6,9	5,4	4,7	3,7	3,5	2,8	2,7	2,2
- 1.5 m	Outriggers lowered			8,6*	8,6*	6,6*	6,6*	5*	5	3,8*	3,8*
	Outriggers raised			6,8	5,3	4,6	3,6	3,4	2,7	2,7	2,1
- 3.0 m	Outriggers lowered			6,5*	6,5*	5,2*	5,2*	4*	4*	2,8*	2,8*
	Outriggers raised			6,5*	5,3	4,5	3,6	3,4	2,7	2,7	2,2

The specified max. loading capacities in tonnes include a stability of 25% or are calculated at 87% of the hydraulic lifting power, as per ISO10567. These values are applicable at the tip of the arm (without Bucket tipping cylinder, system of redirect levers) with optimum positioning of the corresponding arm system and with the pressure switched on. Weights of attached load carrying accessories (grab, magnet, load hook, etc.) are not included with the load carrying values. * Value limited due to hydraulics.

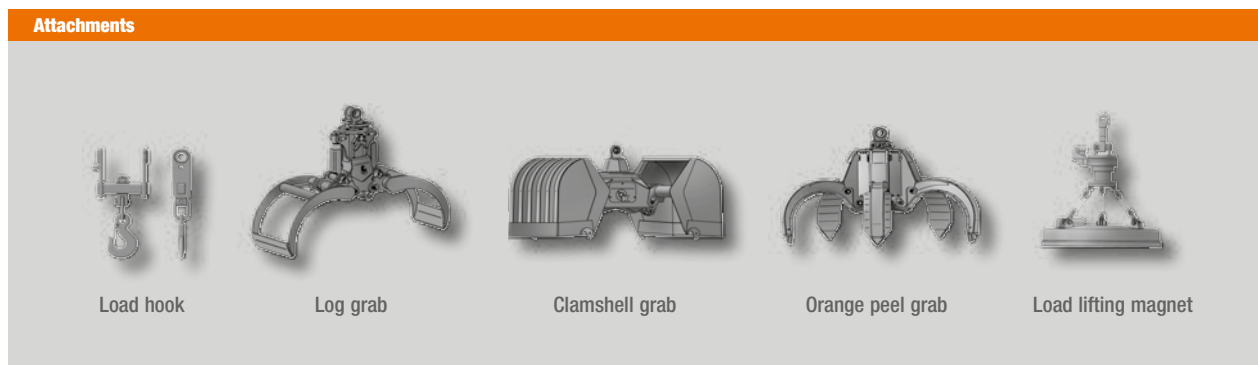

WORKING RANGES 250MH

Working ranges Loading boom 6.20 m (C24.5i) and Stick 4.80 m (D21.15is)

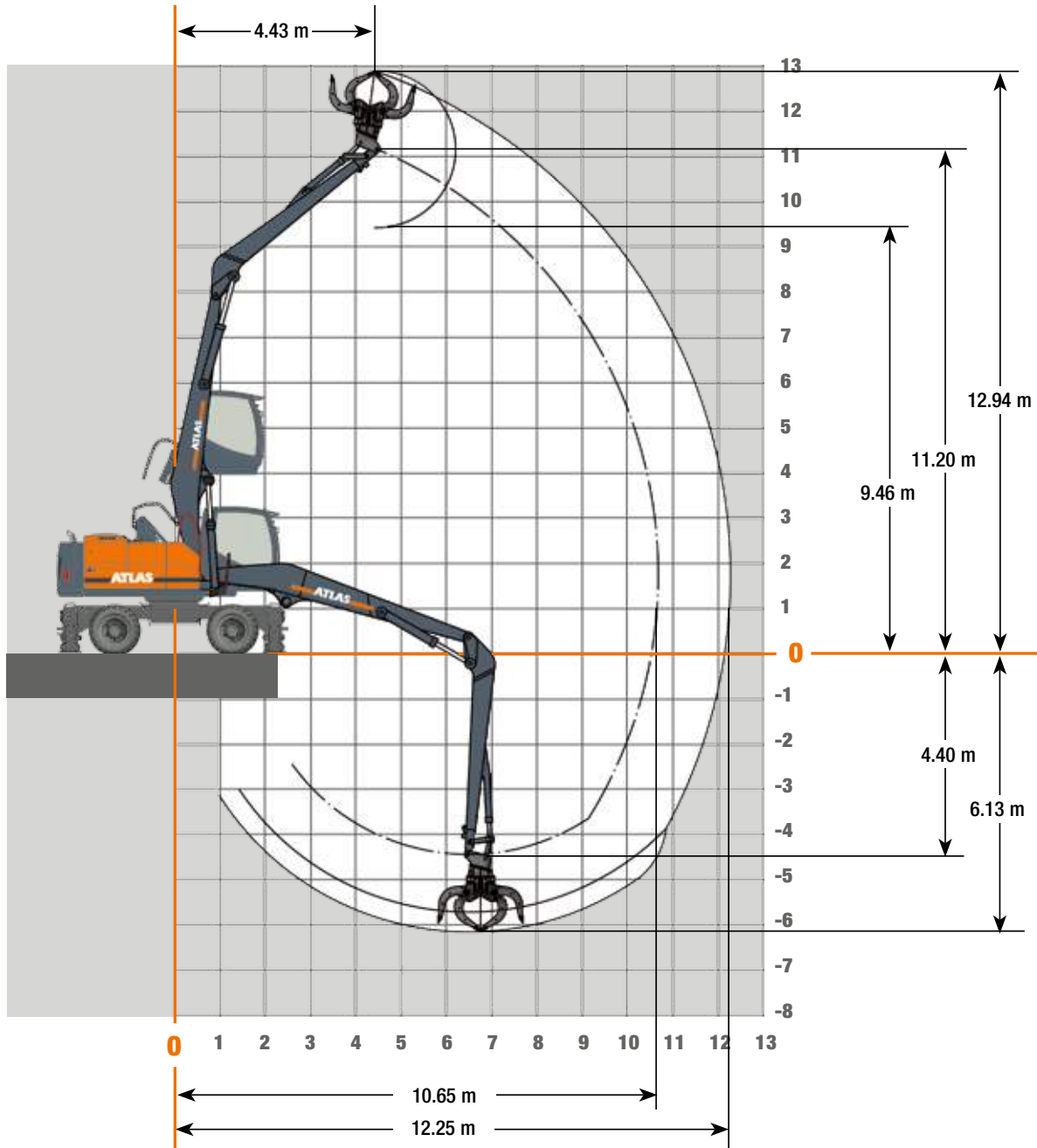

LIFTING CAPACITIES 250MH

Lifting Capacities Loading boom 6.20 m (C24.5i) and Stick 4.80 m (D21.15is)

Lifting Capacities Loading boom 6.20 m (C24.5i) with stick 4.80 m (D21.15is). Max. reach 12.30 m											
HEIGHT		3,0 m		4,5 m		6,0 m		7,5 m		9,0 m	
		FRONT	LATERAL	FRONT	LATERAL	FRONT	LATERAL	FRONT	LATERAL	FRONT	LATERAL
12,0 m	Outriggers lowered										
	Outriggers raised										
10,5 m	Outriggers lowered										
	Outriggers raised										
9,0 m	Outriggers lowered					6,2*	6,2*	5,4*	5,4*		
	Outriggers raised					5,6	4,7	3,9	3,3		
7,5 m	Outriggers lowered					6,1*	6,1*	5,4*	5,4*	4,7*	4,2
	Outriggers raised					5,7	4,7	4	3,3	3	2,4
6,0 m	Outriggers lowered					6,3*	6,3*	5,4*	5,4*	4,7*	4,2
	Outriggers raised					5,6	4,6	4	3,3	3	2,4
4,5 m	Outriggers lowered			8,4*	8,4*	6,7*	6,7*	5,6*	5,5	4,8*	4,2
	Outriggers raised			8,4*	6,9	5,4	4,4	3,9	3,1	2,4	3
3,0 m	Outriggers lowered	14,8*	14,8*	9,6*	9,6*	7,2*	7,2*	5,8*	5,4	4,8*	4,1
	Outriggers raised	14,8*	11,8	7,9	6,4	5,2	4,2	3,7	3	2,8	2,3
1,5 m	Outriggers lowered	2,9*	2,9*	10,4*	10,4*	7,5*	7,3	5,9*	5,2	4,7*	4
	Outriggers raised	2,9*	2,9*	7,4	5,8	4,9	3,9	3,6	2,9	2,8	2,2
0 m	Outriggers lowered			10*	10*	7,4*	7,1	5,7*	5,1	4,4*	4
	Outriggers raised			7	5,5	4,7	3,7	3,5	2,8	2,7	2,2
- 1,5 m	Outriggers lowered			8,7*	8,7*	6,6*	6,6*	5,1*	5	3,8*	3,8*
	Outriggers raised			6,8	5,3	4,6	3,7	3,4	2,8	2,1	2,7
- 3,0 m	Outriggers lowered			6,5*	6,5*	5,2*	5,2*	4*	4*	2,8*	2,8*
	Outriggers raised			6,5*	5,3	4,6	3,6	3,4	2,7	2,7	2,2
- 4,5 m	Outriggers lowered										
	Outriggers raised										

The specified max. loading capacities in tonnes include a stability of 25% or are calculated at 87% of the hydraulic lifting power, as per ISO10567.

These values are applicable at the tip of the arm (without Bucket tipping cylinder, system of redirect levers) with optimum positioning of the corresponding arm system and with the pressure switched on. Weights of attached load carrying accessories (grab, magnet, load hook, etc.) are not included with the load carrying values. * Value limited due to hydraulics.

Attachments



Load hook

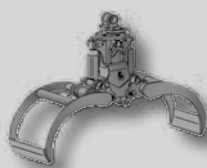

Log grab

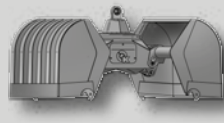

Clamshell grab

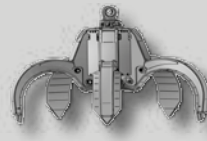

Orange peel grab



Load lifting magnet

WORKING RANGES 250MH

Working ranges Loading boom 6.80 m (C24.6i) and Stick 5.30 m (D21.16i)

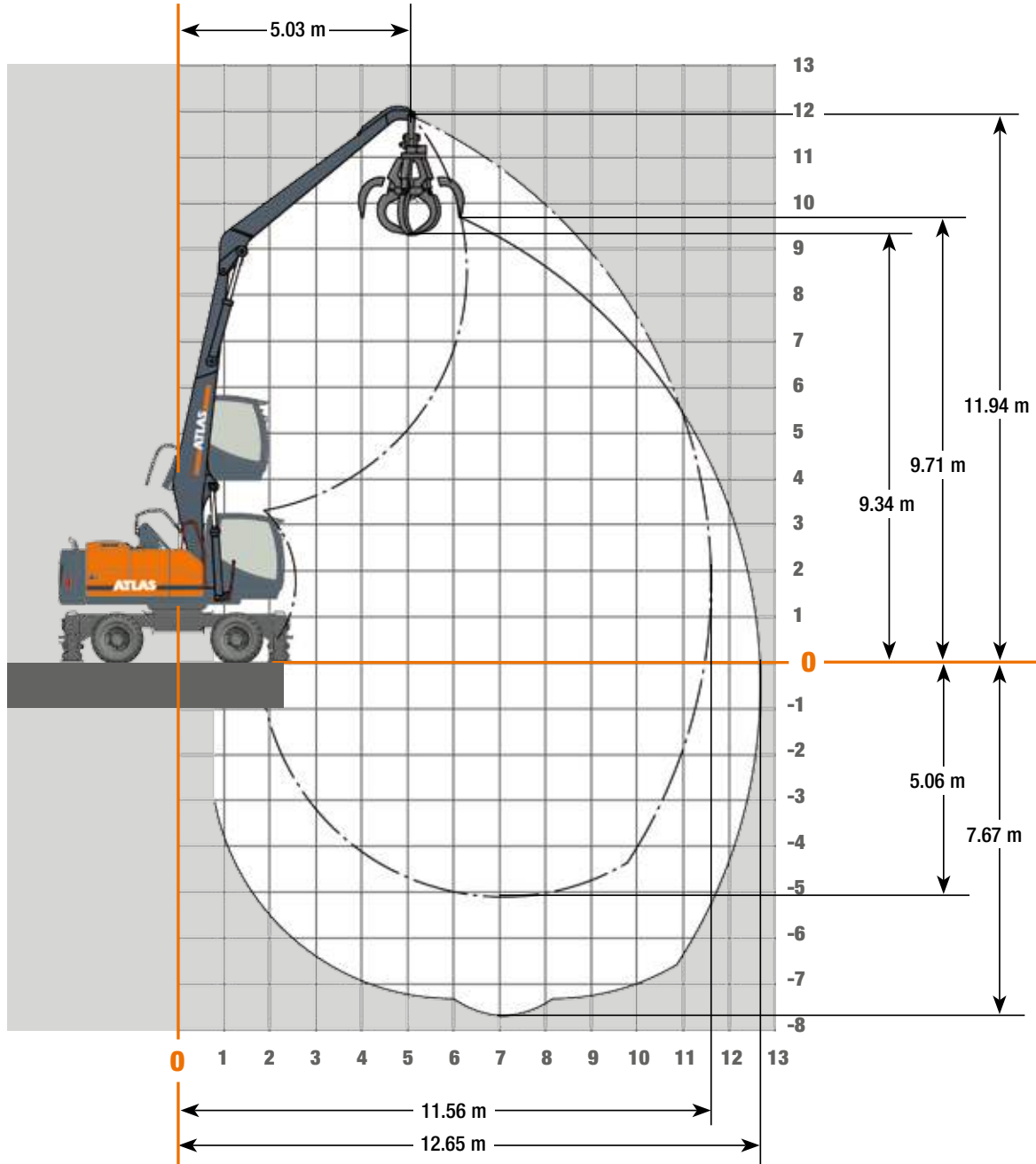

LIFTING CAPACITIES 250MH

Lifting Capacities Loading boom 6.80 m (C24.6i) and Stick 5.30 m (D21.16i)

Lifting Capacities Loading boom 6.80 m (C24.6i) with stick 5.30 m (D21.16i). Max. reach 12.65 m													
HEIGHT		3,0 m		4,5 m		6,0 m		7,5 m		9,0 m		10,5 m	
		FRONT	LATERAL	FRONT	LATERAL	FRONT	LATERAL	FRONT	LATERAL	FRONT	LATERAL	FRONT	LATERAL
12,0 m	Outriggers lowered												
	Outriggers raised												
10,5 m	Outriggers lowered					5,9*	5,9*						
	Outriggers raised					5,7	4,7						
9,0 m	Outriggers lowered							5*	5*				
	Outriggers raised							4	3,3				
7,5 m	Outriggers lowered							5*	5*	4,4*	4,3		
	Outriggers raised							4	3,3	3	2,5		
6,0 m	Outriggers lowered					6*	6*	5,2*	5,2*	4,5*	4,2	3,9*	3,3
	Outriggers raised					5,6	4,6	4	3,3	3	2,4	2,3	1,9
4,5 m	Outriggers lowered			8,2*	8,2*	6,5*	6,5*	5,4*	5,4*	4,6*	4,2	3,9*	3,3
	Outriggers raised			8,2*	6,9	5,4	4,4	3,8	3,2	2,9	2,4	2,3	1,8
3,0 m	Outriggers lowered	14,7*	14,7*	9,4*	9,4*	7*	7*	5,6*	5,3	4,6*	4	3,9*	3,2
	Outriggers raised	14,7*	11,6	7,9	6,3	5,1	4,1	3,7	3	2,8	2,3	2,2	1,8
1,5 m	Outriggers lowered			10,1*	10,1*	7,3*	7,2	5,7*	5,1	4,6*	3,9	3,8*	3,2
	Outriggers raised			7,2	5,6	4,8	3,8	3,5	2,8	2,7	2,2	2,2	1,7
0 m	Outriggers lowered			9,8*	9,8*	7,2*	6,9	5,6*	5	4,4*	3,9	3,5*	3,1
	Outriggers raised			6,7	5,2	4,5	3,6	3,4	2,7	2,6	2	2,1	1,7
- 1,5 m	Outriggers lowered			8,5*	8,5*	6,5*	6,5*	5*	4,9	4*	3,9		
	Outriggers raised			6,6	5	4,4	3,5	3,3	2,6	2,6	2		
- 3,0 m	Outriggers lowered			6,6*	6,6*	5,4*	5,4*	4,2*	4,2*	3,2*	3,2*		
	Outriggers raised			6,5	5	4,3	3,4	3,2	2,6	2,5	2		
- 4,5 m	Outriggers lowered					3,7*	3,7*	3*	3*	2*	2*		
	Outriggers raised					3,7*	3,4	3*	2,6	2*	2		

The specified max. loading capacities in tonnes include a stability of 25% or are calculated at 87% of the hydraulic lifting power, as per ISO10567. These values are applicable at the tip of the arm (without Bucket tipping cylinder, system of redirect levers) with optimum positioning of the corresponding arm system and with the pressure switched on. Weights of attached load carrying accessories (grab, magnet, load hook, etc.) are not included with the load carrying values. * Value limited due to hydraulics.

Attachments



Load hook

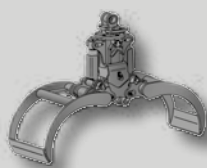

Log grab

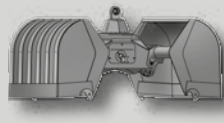

Clamshell grab

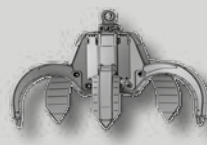

Orange peel grab



Load lifting magnet





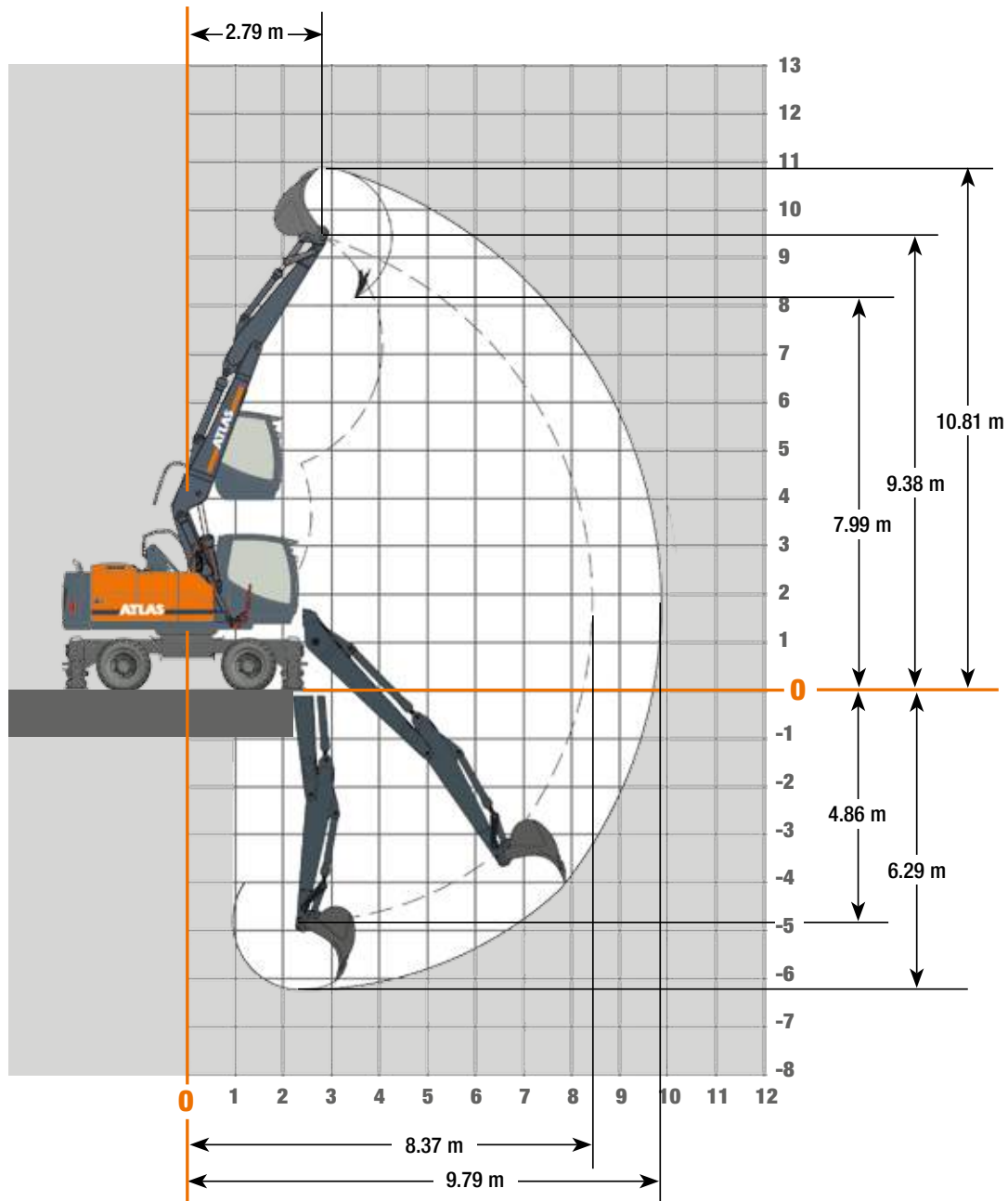



































WORKING RANGES 250MH

Working ranges Adjustable boom: Base arm 1.95 m (C21.41) and boom 3.83 m (C21.461) with stick 2.65 m (D21.33)



LIFTING CAPACITIES 250MH

Lifting Capacities Adjustable boom: Base arm 1.95 m (C21.41) and boom 3.83 m (C21.461) with stick 2.65 m (D21.33)

Lifting Capacities Adjustable boom: Base arm 1.95 m (C21.41) and boom 3.83 m (C21.461) with stick 2.65 m (D21.33). Max reach 9.79 m														
Height	Undercarriage type		3,0 m	3,5 m	4,0 m	4,5 m	5,0 m	5,5 m	6,0 m	6,5 m	7,0 m	7,5 m	8,0 m	
+ 9,0 m	FRONT	 SDB supported		6869										
		 SDB raised		6869										
	LATERAL	 SDB supported		6869										
		 SDB raised		6869										
+7,5 m	FRONT	 SDB supported				5413	5420	5470	4090					
		 SDB raised				5413	5420	5470	4090					
	LATERAL	 SDB supported				5413	5420	5470	4090					
		 SDB raised				5413	5420	5187*	4090					
+6,0 m	FRONT	 SDB supported			5733	5587	5461	5358	5281	5240	4972			
		 SDB raised			5733	5587	5461	5358	5281	4911*	4332*			
	LATERAL	 SDB supported			5733	5587	5461	5358	5281	5240	4972			
		 SDB raised			5733	5587	5461	5201*	4597*	4066*	3558*			
+ 4,5 m	FRONT	 SDB supported	8632	7957	7233	6695	6281	5956	5698	5494	5337	5231		
		 SDB raised	8632	7957	7233	6695	6281	5956	5441*	4871*	4402	3900*		
	LATERAL	 SDB supported	8632	7957	7233	6695	6281	5956	5698	5494	5337	5231		
		 SDB raised	8632	7957	7233	6695	5817*	5111*	4545*	4086*	3633*	3203*		
+ 3,0 m	FRONT	 SDB supported	8540	9515	9611	8403	7547	6910	6420	6034	5725	5466	5260	
		 SDB raised	8540	9515	9358*	7918*	6839	6009	5354*	4818*	4383	3894*	3471	
	LATERAL	 SDB supported	8540	9515	9611	8403	7547	6910	6420	6034	5725	5462*	4970*	
		 SDB raised	8540	9188*	7637	6525*	5674*	5013*	4480*	4050*	3623*	3201*	2839*	
+ 1,5 m	FRONT	 SDB supported	11468	11439	11078	9854	8685	7804	7120	6577	6135	5753	5446	
		 SDB raised	11468	11221	9210*	7799*	6751*	5949*	5313	4809*	4309*	3827*	3422*	
	LATERAL	 SDB supported	11468	11439	11078	9854	8685	7804	7120	6577	5956*	5449	4918*	
		 SDB raised	11303	9028*	7510*	6422*	5605*	4965*	4458*	4032*	3544*	3137*	2792*	
+ 0 m	FRONT	 SDB supported	14157	13121	11822	10349	9186	8252	7495	6870	6343	5894	5470	
		 SDB raised	14157	11290*	9238*	7816*	6776*	5987	5388*	4714*	4171*	3721*	3348*	
	LATERAL	 SDB supported	14157	13121	11822	10349	9186	8244	7328*	6589	6004	5372*	4843*	
		 SDB raised	11393*	9085*	7547*	6455*	5643*	5004*	4419*	3864*	3408*	3032*	2718*	
-1,5 m	FRONT	 SDB supported	16697	13988	11965	10450	9276	8341	7583	6977	6423	5616		
		 SDB raised	14769*	11528*	9438*	7930*	6818*	5894*	5132*	4529*	4035*	3642*		
	LATERAL	 SDB supported	16697	13988	11965	10450	9276	8329*	7461	6613*	5876*	5290*		
		 SDB raised	11332*	9000*	7448*	6336*	5495*	4781*	4169*	3672*	3271*	2952*		
-3,0 m	FRONT	 SDB supported	17200	14332	12312	10832	9585	8455	7325	6054				
		 SDB raised	14886*	11470*	9266*	7683*	6519*	5656*	4978*	4442*				
	LATERAL	 SDB supported	17200	14332	12312	10832	9585	8455	7325	6054				
		 SDB raised	11188*	8870*	7291*	6106*	5214*	4545*	4013*	3590*				
-4,5 m	FRONT	 SDB supported	15161											
		 SDB raised	14748*											
	LATERAL	 SDB supported	15161											
		 SDB raised	11068*											

The specified max. loading capacities in kilogrammes (kg) include a stability of 25% or are calculated at 87% of the hydraulic lifting power, as per ISO10567. These values are applicable at the tip of the arm with optimum positioning of the corresponding arm system. Weights of attached load carrying accessories (grab, magnet, load hook, etc.) are not included with the load carrying values. *Value limited due to excavator stability.

Attachments



Load hook

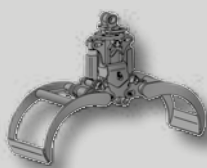

Log grab

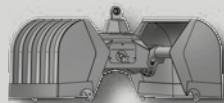

Clamshell grab

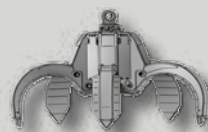

Orange peel grab



Load lifting magnet

DIMENSIONS 250MH

Dimensions [m]

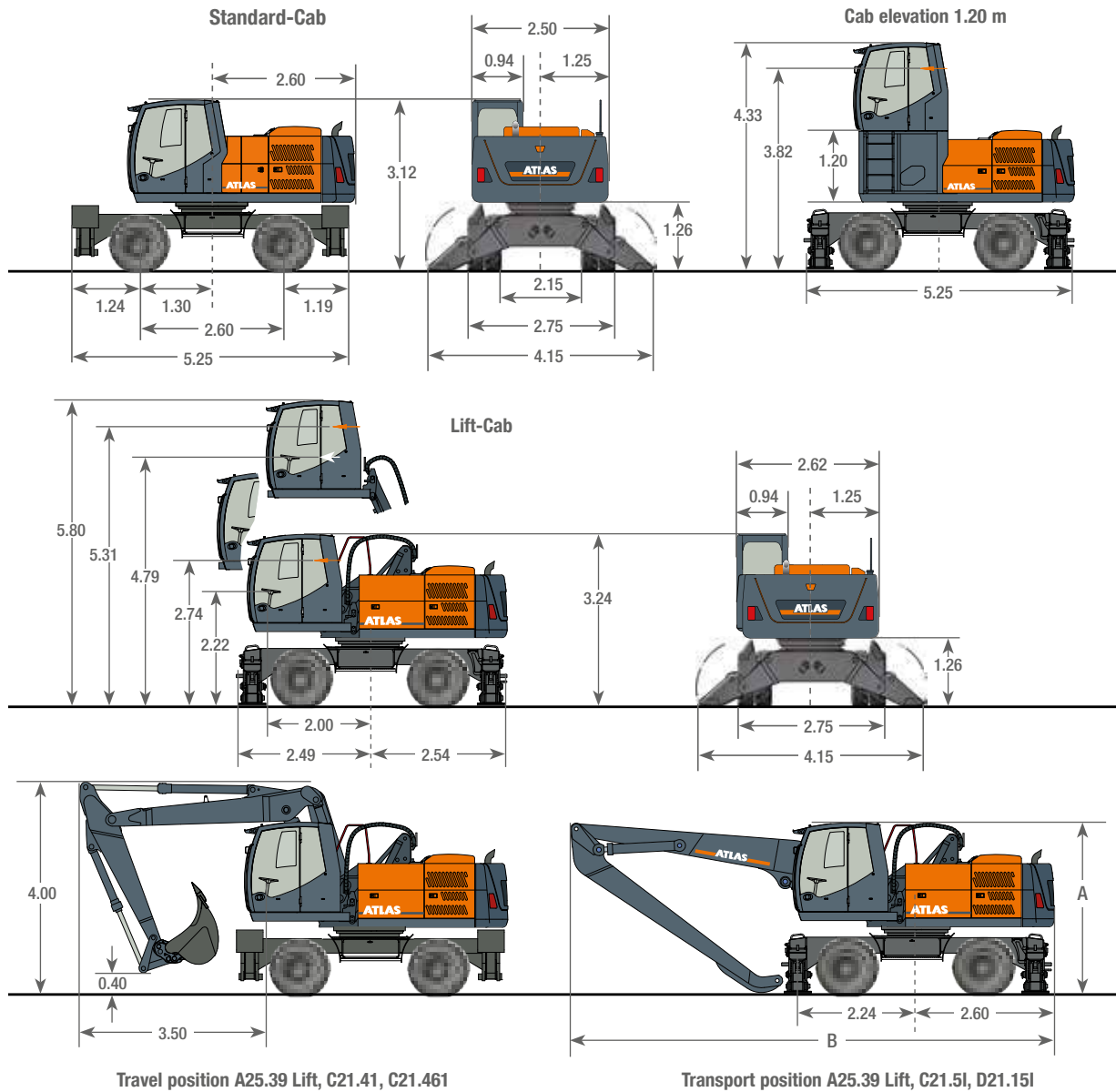

A	TRANSPORT HEIGHT	B	TRANSPORT LENGTH
	Loading boom 6.20 m with Stick 4.80 m.....3.24 m		Loading boom 6.20 with Stick 4.80 m.....9.20 m
	Loading boom 6.80 m with Stick 5.30 m3.24 m		Loading boom 6.80 with Stick 5.30 m.....9.80 m
	Adjustable Boom 1.95 m / 3,83 m with stick 2.65 m3.24 m		Adjustable Boom 1.95 m / 3,83 m with stick 2.65 m ...9.00 m

Further cabin versions on demand.

GANDERKESEE FACTORY

Atlas GmbH
Atlasstraße 6
D-27777 Ganderkesee,
Germany

Tel.: +49 (0) 4222 954 0
Fax: +49 (0) 4222 954 220
E-mail: info@atlasgmbh.com
www.atlasgmbh.com



VECHTA FACTORY

Atlas GmbH
Theodor-Heuss-Str. 3
D-49377 Vechta
Germany

T: +49 (0) 4441 954 0
F: +49 (0) 4441 954 299
E-mail: info@atlasgmbh.com
www.atlasgmbh.com



DELMENHORST FACTORY

Atlas GmbH
Stedinger Straße 324
D-27751 Delmenhorst
Germany

T: +49 (0) 4221 49 10
F: +49 (0) 4221 49 14 43
E-mail: info@atlasgmbh.com
www.atlasgmbh.com

ATLAS CRANES UK LTD NATIONAL SALES & SERVICE FACILITY

Wharfedale Road,
Euroway Trading Est.
Bradford, England BD4 6SL
United Kingdom

T: +44 8444 99 66 88
F: +44 1274 65 37 85
E-mail: atlasuk@atlasgmbh.com
www.atlas-cranes.co.uk
www.atlasgmbh.com



SINCE 1919
ATLAS



www.atlasgmbh.com

ATLAS GmbH
EXCAVATORS
Atlasstraße 6
D-27777 Ganderkesee, Germany
T: +49 (0) 4222 954 0
Fax: +49 (0) 4222 954 220
info@atlasgmbh.com